



JOHNSON PUMP
AN SPX BRAND

Instruction Manual
Flexible Impeller Pumps
bronze, pedestal mounted

F35B-8, F4B-8, F5B-8, F7B-8, F8B-8



Read and understand this manual prior to operating or servicing this product.

IB-501/01 (0912)

SPX®

INDEX - INDICE

Svenska.....	3
English.....	10
Deutsch.....	17
Français.....	24
Español.....	31
Italiano.....	38

Besök www.johnson-pump.com för mer information om vår världsomspännande organisation, våra godkännanden, certifieringar och lokala representanter. SPX Corporation förbehåller sig rätten att ändra design och material utan föregående avisering. Designelement, konstruktionsmaterial och dimensioner som beskrivs i denna bulletin gäller endast som information och skall alltid bekräftas skriftligt för att vara gällande.

For more information about our worldwide locations, approvals, certifications, and local representatives, please visit www.johnson-pump.com. SPX Corporation reserves the right to incorporate our latest design and material changes without notice or obligation. Design features, materials of construction and dimensional data, as described in this bulletin, are provided for your information only and should not be relied upon unless confirmed in writing.

Für weitere Informationen über unsere weltweiten Standorte, Zulassungen, Zertifizierungen und unsere Vertreter vor Ort, besuchen Sie bitte unsere Webseite: www.johnson-pump.com. Die SPX Corporation behält sich das Recht vor, die neuesten Konstruktions- und Werkstoffänderungen ohne vorherige Ankündigung und ohne Verpflichtung hierzu einfließen zu lassen. Konstruktive Ausgestaltungen, Werkstoffe sowie Maßangaben, wie sie in dieser Mitteilung beschrieben sind, sind nur zur Information. Alle Angaben sind unverbindlich, es sei denn, sie wurden schriftlich bestätigt.

Pour plus d'information sur nos succursales internationales, nos approbations, nos certifications et nos représentants locaux, veuillez consulter notre site Internet au www.johnson-pump.com. SPX Corporation se réserve le droit d'incorporer nos plus récents concepts ainsi que tout autre modification importante sans préavis ou obligation. Les éléments décoratifs, matériaux de construction et les données dimensionnelles, tels qu'énoncés dans ce communiqué, sont fournis pour votre information seulement et ne doivent pas être considérés comme officiels à moins d'avis contraire par écrit.

Para más información sobre nuestras oficinas a nivel mundial, aprobaciones, certificaciones y representantes locales, por favor visite www.johnson-pump.com. SPX Corporation se reserva el derecho de incorporar nuestro diseño más reciente y cambios materiales sin necesidad de notificación previa u obligación de ningún tipo. Características de diseño, materiales de construcción y dimensiones, tal y como están descritas en este boletín, son proporcionadas sólo con fines informativos y no deben ser usados como referencia a menos que sean confirmados por escrito.

Per ottenere maggiori informazioni sulle nostre sedi nel mondo, autorizzazioni, certificazioni, e rappresentanti locali, potete visitare il sito www.johnson-pump.com. La SPX Corporation si riserva il diritto di apportare cambiamenti ai propri design e materiali senza preavviso o vincolo. Le caratteristiche del design, i materiali di costruzione e i dati dimensionali, così come descritti nel presente bollettino, sono forniti solo per vostra informazione e non saranno oggetto di obbligazione salvo autorizzazione confermata per iscritto.

Made in Sweden

Garanti 1 år
Warranty 1 year
Garantie 1 Jahr

Garantie 1 an
Garantía 1 año
Garanzia 1 anno

Självsugande flexibel impellerpump i brons, fotmonterad

Typiska användningsområden

- *Marint*
Kylvattenpump, länsypump, spolpump, tömning av septiktankar.
- *Industri och jordbruk*
Transport- och cirkulationspump, tömning av slam- och spillvätske-brunnar, pumpning av förorenade vätskor innehållande fasta partiklar.

Teknisk beskrivning

Pumphus:	Brons
Impeller:	Neopren, EPDM alt nitril
Axel:	Syrafast stål Axeln är lagrad i två permanentmorda dubbla kullager
Tätning:	Läpptätning alt. mekanisk tätning
Kam:	Hel alt reducerad
Anslutning:	Se "Modellspecifikation", sid 4

Tryck- och kapacitetsdata

Se sid 45-47

Serviceinstruktion

Se reservdelslista sid 5-9

Demontering

1. Lossa pumplocket och tag bort o-ringen
2. Tag ur impellern med t ex två skruvmejslar.
3. Demontera kammen och tag bort tätningemedlet på kammen och i pumphuset. Tag även bort slitbrickan.
4. Demontera läpptätningen alt. mekaniska tätningen.
5. Demontera brickan (pos 9 för F35B-8 - F7B-8 resp pos 10 för F8B-8) genom att slå in en mejsel genom urgjutningen och bänd ut brickan.
6. Demontera låsringen som håller lagerpaketet.

7. Demontera axeln med kullager genom att pressa på axeländen från impellersidan.
8. Demontera kullagren/låsringen och distanshylsan. På F35B-8, F4B-8 och F8B-8 får inte kullagren pressas över tätningssytan.
9. Tag bort o-ringen på axeln.

Montering

1. Montera kullagren/låsringen och distanshylsan på axeln. På F35B-8, F4B-8 och F8B-8 får inte lagren pressas över tätningssytan.
2. Montera o-ringen på axeln (gäller ej F8B-8).
3. Pressa i axeln med kullagren i pumphuset och montera låsringen samt bricka (pos 9 för F35B-8 - F7B-8 resp pos 10 för F8B-8). Montera o-ringen pos 21 (gäller endast F8B-8)
4. Montera läpptätningen (fjäders i läpptätningen ska vara vänd mot impellern) alt mekaniska tätningen. Montera slitbrickan .
5. Skruva fast kammen, men lägg först på tätningemedel på kam och kamskruv för att förhindra läckage.
6. Smörj impellern med JP Impeller Lubricant och montera med roterande rörelse i impellers rotationsriktning.
7. Montera o-ringen och skruva fast locket.

Avfallshantering/ materialåtervinning

Vid avfallshantering ska produkten lämnas för destruktion/återvinning enligt gällande lagstiftning. Vid tillämpliga fall demonteras och sorteras produkten i ingående materialfraktioner.

Modellspecifikation

F35B-8 Pump typ	Order Nr. Läpptätning	Order Nr. Mek.tätning	Impeller	Kam	Pumphus	Anslutning
F35B-8	10-24569-13	10-24569-01	Neopren	1	01-35881-1	ISO7/1-Rp3/8
F35B-802	10-24569-15	10-24569-03	Neopren	1/2	01-35881-1	ISO7/1-Rp3/8
F35B-8007	10-24569-52	10-24569-51	Neopren	1	01-35881-2	3/8-18NPTF
F35B-8027	10-24569-21	10-24569-09	Neopren	1/2	01-35881-2	3/8-18NPTF

F4B-8 Pump typ	Order Nr. Läpptätning	Order Nr. Mek.tätning	Impeller	Kam	Pumphus	Anslutning
F4B-8	10-24570-13	10-24570-01	Neopren	1	01-35882-1	ISO7/1-Rp3/8
F4B-89	10-24570-14	10-24570-02	Nitril	1	01-35882-1	ISO7/1-Rp3/8
F4B-8007	10-24570-19	10-24570-07	Neopren	1	01-35882-2	3/8-18NPTF
F4B-8007	10-24570-52	10-24570-51	Neopren	1	01-35882-2	3/8-18NPTF

F5B-8 Pump typ	Order Nr. Läpptätning	Order Nr. Mek.tätning	Impeller	Kam	Pumphus	Anslutning
F5B-8	10-24571-13	10-24571-01	Neopren	1	01-24573-1	ISO7/1-Rp3/4
F5B-89	10-24571-14	10-24571-02	Nitril	1	01-24573-1	ISO7/1-Rp3/4
F5B-802	10-24571-15	10-24571-03	Neopren	1/2	01-24573-1	ISO7/1-Rp3/4
F5B-8007	10-24571-52	10-24571-51	Neopren	1	01-24573-2	3/4-14NPTF

F7B-8 Pump typ	Order Nr. Läpptätning	Order Nr. Mek.tätning	Impeller	Kam	Pumphus	Anslutning
F7B-8	10-24572-13	10-24572-01	EPDM	1	01-24574-3	ISO7/1-Rp1
F7B-8007	10-24572-52	10-24572-51	EPDM	1	01-24574-4	1-11 1/2NPTF

F8B-8 Pump typ	Order Nr. Läpptätning	Order Nr. Mek.tätning	Impeller	Kam	Pumphus	Anslutning
F8B-8		10-13021-1	Neopren	1	01-13164-1	ISO7/1-Rp11/2
F8B-8007		10-13021-9	Neopren	1	01-13164-2	11/2-111/2NPTF
F8B-8007		10-13021-95	Neopren	1	01-13164-3	11/4-111/2NPTF
F8B-8007		10-13021-96	Neopren	1	01-13164-4	11/2-111/2NPTF

Reservdelsslista

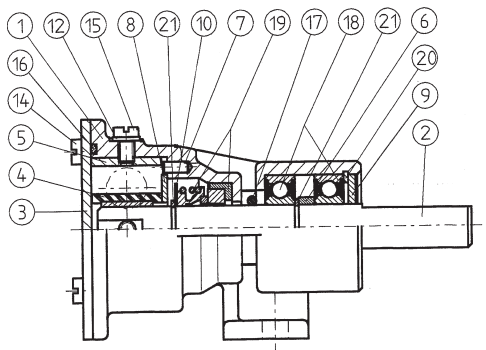

F35B-8

Pos	Antal	Benämning	10-24569-13	10-24569-15	10-24569-52	10-24569-21	Läpptätning Mektätning
			10-24569-01	10-24569-03	10-24569-51	10-24569-09	
1	1	Pumphus	01-35881-1	01-35881-1	01-35881-2	01-35881-2	
2	1	Axel	01-46735-1	01-46735-1	01-46740	01-46735-1	
3	1	Lock	01-46739-2	01-46739-2	01-46739-2	01-46739-2	
4	1	Impeller	09-808B	09-808B	09-808B	09-808B	
5	1	Kam	01-42910	01-42415	01-42910	01-42415	
6	1	Distansring	01-45542	01-45542	01-45542	01-45542	
7	1	Stift	01-42400	01-42400	01-42400	01-42400	
8	1	Slitbricka	01-46676	01-46676	01-46676	01-46676	
9	1	Bricka	01-45049	01-45049	01-45049	01-45049	
10	1	Bricka					
10	1	Bricka	01-45659	01-45659	01-45659	01-45659	
12	1	Bricka	01-46790-01	01-46790-01	01-46790-01	01-46790-01	
14	4	Skruv	0.0279.300	0.0279.300	0.0279.300	0.0279.300	
15	1	Skruv	01-46974-03	01-46794-10	01-46794-03	01-46794-10	
16	1	O-ring	0.2173.440	0.2173.440	0.2173.440	0.2173.440	
17	1	O-ring	0.2173.432	0.2173.432	0.2173.432	0.2173.432	
18	2	Kullager	0.3431.748	0.3431.748	0.3431.748	0.3431.748	
19	1	Läpptätning	0.2233.010	0.2233.010	0.2233.010	0.2233.010	
19	1	Mek.tätning	0.2247.021	0.2247.021	0.2247.021	0.2247.021	
20	1	Låsring	0.0371.028	0.0371.028	0.0371.028	0.0371.028	
21	1	Låsring	0.0370.012	0.0370.012	0.0370.012	0.0370.012	
21	2	Låsring	0.0370.012	0.0370.012	0.0370.012	0.0370.012	

Reservdelssats:

4,14,16&19	09-45589	09-45589	09-45589	09-45589	Läpptätning
4,14,16&19	09-46840	09-46840	09-46840	09-46840	Mektätning

Reservdelslista

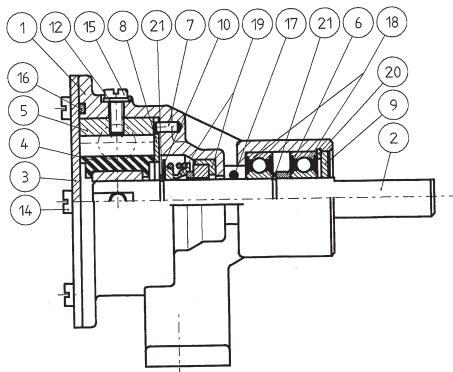

F4B-8

Pos	Antal	Benämning	10-24570-13	10-24570-14	10-24570-19	10-24570-52	Läpptätning
			10-24570-01	10-24570-02	10-24570-07	10-24570-51	
1	1	Pumphus	01-35882-1	01-35882-1	01-35882-2	01-35882-2	
2	1	Axel	01-46735-1	01-46735-1	01-46735-1	01-46740	
3	1	Lock	01-46007-2	01-46007-2	01-46007-2	01-46007-2	
4	1	Impeller	09-810B	09-810B-9	09-810B	09-810B	
5	1	Kam	01-42389	01-42389	01-42389	01-42389	
6	1	Distansring	01-45542	01-45542	01-45542	01-45542	
7	1	Stift	01-42400	01-42400	01-42400	01-42400	
8	1	Slitbricka	01-46737-2	01-46737-2	01-46737-2	01-46737-2	
9	1	Bricka	01-45049	01-45049	01-45049	01-45049	
10	1	Bricka					
10	1	Bricka	01-45659	01-45659	01-45659	01-45659	
12	1	Bricka	01-46790-01	01-46790-01	01-46790-01	01-46790-01	
14	6	Skruv	0.0279.300	0.0279.300	0.0279.300	0.0279.300	
15	1	Skruv	01-46794-04	01-46794-04	01-46794-04	01-46794-04	
16	1	O-ring	0.2173.476	0.2173.476	0.2173.476	0.2173.476	
17	1	O-ring	0.2173.432	0.2173.432	0.2173.432	0.2173.432	
18	2	Kullager	0.3431.748	0.3431.748	0.3431.748	0.3431.748	
19	1	Läpptätning	0.2233.010	0.2233.010	0.2233.010	0.2233.010	
19	1	Mektätning	0.2247.021	0.2247.021	0.2247.021	0.2247.021	
20	1	Låsring	0.0371.028	0.0371.028	0.0371.028	0.0371.028	
21	1	Låsring	0.0370.012	0.0370.012	0.0370.012	0.0370.012	
21	2	Låsring	0.0370.012	0.0370.012	0.0370.012	0.0370.012	

Reservdelsatts:

4,14,16 & 19	09-45587	09-45588	09-45587	09-45587	Läpptätning
4,14,16 & 19	09-46841	09-46842	09-46841	09-46841	Mektätning

Reservdelista

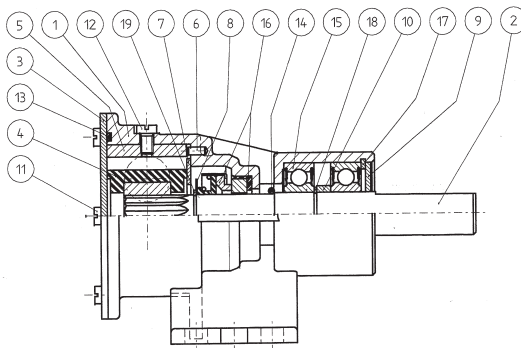

F5B-8

Pos	Antal	Benämning	10-24571-13	10-24571-14	10-24571-15	10-24571-52	Läpptätning
			10-24571-01	10-24571-02	10-24571-03	10-24571-51	Mektätning
1	1	Pumphus	01-24573-1	01-24573-1	01-24573-1	01-24573-2	
2	1	Axel	01-46744	01-46744	01-46744	01-46746	
3	1	Lock	01-46747-2	01-46747-2	01-46747-2	01-46747-2	
4	1	Impeller	09-1027B	09-1027B-9	09-1027B	09-1027B	
5	1	Kam	01-42397	01-42397	01-45014	01-42397	
6	1	Stift	01-42400	01-42400	01-42400	01-42400	
7	1	Slitbricka	01-42399-2	01-42399-2	01-42399-2	01-42399-2	
8	1	Bricka					
8	1	Bricka	01-45680	01-45680	01-45680	01-45680	
9	1	Bricka	01-45047	01-45047	01-45047	01-45047	
10	1	Distansring	01-46009	01-46009	01-46009	01-46009	
11	6	Skruv	0.0279.300	0.0279.300	0.0279.300	0.0279.300	
12	1	Skruv	01-46794-05	01-46794-05	0.0279.032	01-46794-05	
13	1	O-ring	0.2173.475	0.2173.475	0.2173.475	0.2173.475	
14	1	O-ring	0.2173.402	0.2173.402	0.2173.402	0.2173.402	
15	2	Kullager	0.3431.742	0.3431.742	0.3431.742	0.3431.742	
16	1	Läpptätning	0.2233.012	0.2233.012	0.2233.012	0.2233.012	
16	1	Mektätning	0.2247.022	0.2247.022	0.2247.022	0.2247.022	
17	1	Låsring	0.0371.040	0.0371.040	0.0371.040	0.0371.040	
18	1	Låsring	0.0370.017	0.0370.017	0.0370.017	0.0370.017	
19	1	Låsring					
19	1	Låsring	0.0370.516	0.0370.516	0.0370.516	0.0370.516	

Reservdelssats:

4,11,13 & 16	09-45585	09-45586	09-45585	09-45585	Läpptätning
4,11,13 & 16	09-46843	09-46844	09-46843	09-46843	Mektätning

Reservdelslista

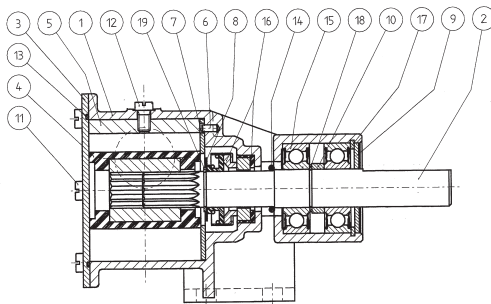

F7B-8

Pos	Antal	Benämning	10-24572-13	10-24572-52	Läpptätning
			10-24572-01	10-24572-51	Mek.tätning
1	1	Pumphus	01-24574-3	01-24574-4	
2	1	Axel	01-46744	01-46746	
3	1	Lock	01-46648-3	01-46648-3	
4	1	Impeller	09-1028BT-1	09-1028BT-1	
5	1	Kam	01-42679	01-42679	
6	1	Stift	01-42400	01-42400	
7	1	Slitbricka	01-46798-2	01-46798-2	
8	1	Bricka			
8	1	Bricka	01-45680	01-45680	
9	1	Bricka	01-45047	01-45047	
10	1	Distansring	01-46009	01-46009	
11	6	Skruv	0.0279.301	0.0279.301	
12	1	Skruv	01-46794-01	01-46794-01	
13	1	O-ring	0.2172.012	0.2172.012	
14	1	O-ring	0.2173.402	0.2173.402	
15	2	Kullager	0.3431.742	0.3431.742	
16	1	Läpptätning	0.2233.012	0.2233.012	
16	1	Mek.tätning	0.2247.022	0.2247.022	
17	1	Låsring	0.0371.040	0.0371.040	
18	1	Låsring	0.0370.017	0.0370.017	
19	1	Låsring			
19	1	Låsring	0.0370.516	0.0370.516	

Reservdelssets:

4,11,13 & 16	09-47426	09-47426	Läpptätning
4,11,13 & 16	09-47427	09-47427	Mek.tätning

Reservdelslista

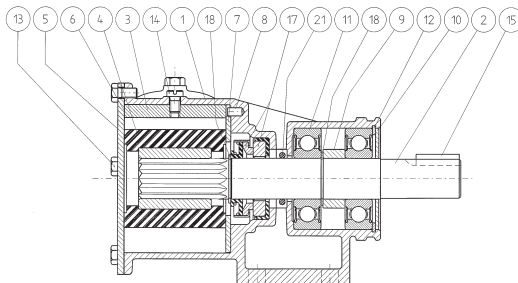

			F8B-8	F8B-8007	F8B-8007	F8B-8007
Pos	Antal	Benämning	10-13021-1	10-13021-9	10-13021-95	10-13021-96
1	1	Pumphus	01-13164-1	01-13164-2	01-13164-3	01-13164-4
2	1	Axel	01-35132	01-35132	01-35746	01-35746
3	1	Kam	01-42680	01-42680	01-42680	01-42680
4	1	Impeller	09-819B	09-819B	09-819B	09-819B
5	1	Lock	01-42422-1	01-42422-1	01-42422-1	01-42422-1
6	1	Packning	01-42424	01-42424	01-42424	01-42424
7	1	Slitbricka	01-42423	01-42423	01-42423	01-42423
8	1	Stift	01-42426	01-42426	01-42426	01-42426
9	1	Distansring	01-45374	01-45374	01-45374	01-45374
10	1	Bricka	01-45380	01-45380	01-45380	01-45380
11	2	Kullager	0.3431.780	0.3431.780	0.3431.780	0.3431.780
12	1	Låsring	0.0371.062	0.0371.062	0.0371.062	0.0371.062
13	5	Skruv	0.0138.134	0.0138.134	0.0138.134	0.0138.134
14	1	Skruv	01-46794-02	01-46794-02	01-46794-02	01-46794-02
15	1	Kil	0.0502.231	0.0502.231	-	-
17	1	Mek.tätning	0.2247.008	0.2247.008	0.2247.008	0.2247.008
18	2	Låsring	0.0370.525	0.0370.525	0.0370.525	0.0370.525
21	1	O-ring	0.2172.573	0.2172.573	0.2172.573	0.2172.573
Reservdelsatts:						
		4,6,13,17 & 18	09-45575	09-45575	09-45575	09-45575

Self-priming, flexible impeller pump of bronze, pedestal mounted

Typical applications

- *Marine*
Engine cooling, bilge pump, deck-wash pump, wash-down, emptying holding tanks.
- *Industry*
Liquid circulation and transfer, emptying tanks and sump drainage, handling of solids in suspension.

Design features

Body:	Bronze
Impeller:	Neoprene, EPDM or nitrile
Shaft:	Stainless steel
	The shaft is mounted with two permanently lubricated double ball bearings
Seal:	Lip seal alt. mechanical seal
Cam:	Full or reduced
Connection:	See "Type designation", page 11

Pressure and capacity data

See page 45-47

Service instructions

See parts list page 12-16.

Disassembly

1. Remove the endcover and the o-ring.
2. Pull out the impeller using two screw drivers or other suitable implements.
3. Remove the cam and wash away any traces of sealing compound on the cam and inside the pump body. Remove the wear plate.
4. Remove the lip seal alt mechanical seal.

5. Remove the washer (pos 9 for F35B-8 - F7B-8 and pos 10 for F8B-8) by inserting a screw driver through the slot and lever out the washer.
6. Remove the retaining ring for the bearing assembly.
7. Remove the shaft with ball bearings by pressing on the shaft end from the impeller side.
8. Remove the ball bearings/retaining ring and the spacer. On F35B-8, F4B-8 and F8B-8 do not press the ball bearings over the sealing surface.
9. Remove the o-ring from the shaft.

Assembly

1. Mount the ball bearings/retaining ring and the spacer on the shaft. On F35B-8, F4B-8 and F8B-8 do not press the ball bearings over the sealing surface.
2. Mount the o-ring on the shaft (not on F8B-8)
3. Press the shaft with ball bearings into the body and fit the retaining ring and washer (pos 9 for F35B-8 - F7B-8 and pos 10 for F8B-8). Mount the o-ring pos 21 (only on the F8B-8).
4. Mount the lip seal (spring towards the impeller) alt mechanical seal. Mount the wear plate (pos 18).
5. Fasten the cam, but before doing so apply sealing compound to cam and screw in order to prevent leakage.
6. Lubricate the impeller with JP Impeller Lubricant and fit it with a rotating movement in the intended direction of rotation.
7. Fit the o-ring before mounting the endcover.

Waste handling material recycling

At the products end of life, please dispose of the product according to applicable law. Where applicable, please disassemble the product and recycle the parts material.

Type designation

F35B-8 Pump type	Part No. Lipseal	Part No. Mechanical seal	Impeller	Cam	Body	Connection
F35B-8	10-24569-13	10-24569-01	Neopren	1	01-35881-1	ISO7/1-Rp3/8
F35B-802	10-24569-15	10-24569-03	Neopren	1/2	01-35881-1	ISO7/1-Rp3/8
F35B-8007	10-24569-52	10-24569-51	Neopren	1	01-35881-2	3/8-18NPTF
F35B-8027	10-24569-21	10-24569-09	Neopren	1/2	01-35881-2	3/8-18NPTF

F4B-8 Pump type	Part No. Lipseal	Part No. Mechanical seal	Impeller	Cam	Body	Connection
F4B-8	10-24570-13	10-24570-01	Neopren	1	01-35882-1	ISO7/1-Rp3/8
F4B-89	10-24570-14	10-24570-02	Nitril	1	01-35882-1	ISO7/1-Rp3/8
F4B-8007	10-24570-19	10-24570-07	Neopren	1	01-35882-2	3/8-18NPTF
F4B-8007	10-24570-52	10-24570-51	Neopren	1	01-35882-2	3/8-18NPTF

F5B-8 Pump type	Part No. Lipseal	Part No. Mechanical seal	Impeller	Cam	Body	Connection
F5B-8	10-24571-13	10-24571-01	Neopren	1	01-24573-1	ISO7/1-Rp3/4
F5B-89	10-24571-14	10-24571-02	Nitril	1	01-24573-1	ISO7/1-Rp3/4
F5B-802	10-24571-15	10-24571-03	Neopren	1/2	01-24573-1	ISO7/1-Rp3/4
F5B-8007	10-24571-52	10-24571-51	Neopren	1	01-24573-2	3/4-14NPTF

F7B-8 Pump type	Part No. Lipseal	Part No. Mechanical seal	Impeller	Cam	Body	Connection
F7B-8	10-24572-13	10-24572-01	EPDM	1	01-24574-3	ISO7/1-Rp1
F7B-8007	10-24572-52	10-24572-51	EPDM	1	01-24574-4	1-11 1/2NPTF

F8B-8 Pump type	Part No. Lipseal	Part No. Mechanical seal	Impeller	Cam	Body	Connection
F8B-8		10-13021-1	Neopren	1	01-13164-1	ISO7/1-Rp11/2
F8B-8007		10-13021-9	Neopren	1	01-13164-2	11/2-111/2NPTF
F8B-8007		10-13021-95	Neopren	1	01-13164-3	11/4-111/2NPTF
F8B-8007		10-13021-96	Neopren	1	01-13164-4	11/2-111/2NPTF

Parts list

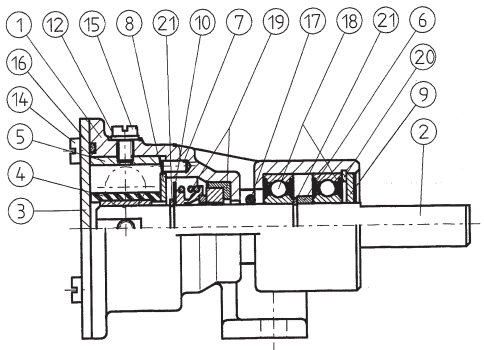

F35B-8

Pos	Nos	Description	10-24569-13	10-24569-15	10-24569-52	10-24569-21	Lipseal
			10-24569-01	10-24569-03	10-24569-51	10-24569-09	Mech. seal
1	1	Body	01-35881-1	01-35881-1	01-35881-2	01-35881-2	
2	1	Shaft	01-46735-1	01-46735-1	01-46740	01-46735-1	
3	1	Endcover	01-46739-2	01-46739-2	01-46739-2	01-46739-2	
4	1	Impeller	09-808B	09-808B	09-808B	09-808B	
5	1	Cam	01-42910	01-42415	01-42910	01-42415	
6	1	Spacer	01-45542	01-45542	01-45542	01-45542	
7	1	Pin	01-42400	01-42400	01-42400	01-42400	
8	1	Wear plate	01-46676	01-46676	01-46676	01-46676	
9	1	Washer	01-45049	01-45049	01-45049	01-45049	
10	1	Washer					
10	1	Washer	01-45659	01-45659	01-45659	01-45659	
12	1	Washer	01-46790-01	01-46790-01	01-46790-01	01-46790-01	
14	4	Screw	0.0279.300	0.0279.300	0.0279.300	0.0279.300	
15	1	Screw	01-46974-03	01-46794-10	01-46794-03	01-46794-10	
16	1	O-ring	0.2173.440	0.2173.440	0.2173.440	0.2173.440	
17	1	O-ring	0.2173.432	0.2173.432	0.2173.432	0.2173.432	
18	2	Ball bearing	0.3431.748	0.3431.748	0.3431.748	0.3431.748	
19	1	Lipseal	0.2233.010	0.2233.010	0.2233.010	0.2233.010	
19	1	Mech. seal	0.2247.021	0.2247.021	0.2247.021	0.2247.021	
20	1	Retainingring	0.0371.028	0.0371.028	0.0371.028	0.0371.028	
21	1	Retainingring	0.0370.012	0.0370.012	0.0370.012	0.0370.012	
21	2	Retainingring	0.0370.012	0.0370.012	0.0370.012	0.0370.012	

Spareparts kit:

4,14,16&19	09-45589	09-45589	09-45589	09-45589	Lipseal
4,14,16&19	09-46840	09-46840	09-46840	09-46840	Mech. seal

Parts list

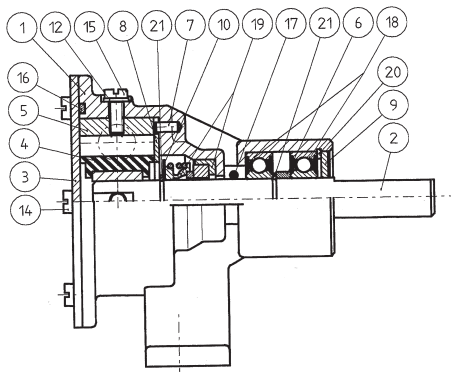

F4B-8

Pos	Nos	Description	10-24570-13	10-24570-14	10-24570-19	10-24570-52	Lipseal
			10-24570-01	10-24570-02	10-24570-07	10-24570-51	Mech. seal
1	1	Body	01-35882-1	01-35882-1	01-35882-2	01-35882-2	
2	1	Shaft	01-46735-1	01-46735-1	01-46735-1	01-46740	
3	1	Endcover	01-46007-2	01-46007-2	01-46007-2	01-46007-2	
4	1	Impeller	09-810B	09-810B-9	09-810B	09-810B	
5	1	Cam	01-42389	01-42389	01-42389	01-42389	
6	1	Spacer	01-45542	01-45542	01-45542	01-45542	
7	1	Pin	01-42400	01-42400	01-42400	01-42400	
8	1	Wearplate	01-46737-2	01-46737-2	01-46737-2	01-46737-2	
9	1	Washer	01-45049	01-45049	01-45049	01-45049	
10	1	Washer					
10	1	Washer	01-45659	01-45659	01-45659	01-45659	
12	1	Washer	01-46790-01	01-46790-01	01-46790-01	01-46790-01	
14	6	Screw	0.0279.300	0.0279.300	0.0279.300	0.0279.300	
15	1	Screw	01-46794-04	01-46794-04	01-46794-04	01-46794-04	
16	1	O-ring	0.2173.476	0.2173.476	0.2173.476	0.2173.476	
17	1	O-ring	0.2173.432	0.2173.432	0.2173.432	0.2173.432	
18	2	Ball bearing	0.3431.748	0.3431.748	0.3431.748	0.3431.748	
19	1	Lipseal	0.2233.010	0.2233.010	0.2233.010	0.2233.010	
19	1	Mech. seal	0.2247.021	0.2247.021	0.2247.021	0.2247.021	
20	1	Retaining ring	0.0371.028	0.0371.028	0.0371.028	0.0371.028	
21	1	Retaining ring	0.0370.012	0.0370.012	0.0370.012	0.0370.012	
21	2	Retaining ring	0.0370.012	0.0370.012	0.0370.012	0.0370.012	

Spareparts kit:

4,14,16 & 19	09-45587	09-45588	09-45587	09-45587	Lipseal
4,14,16 & 19	09-46841	09-46842	09-46841	09-46841	Mech. seal

Parts list

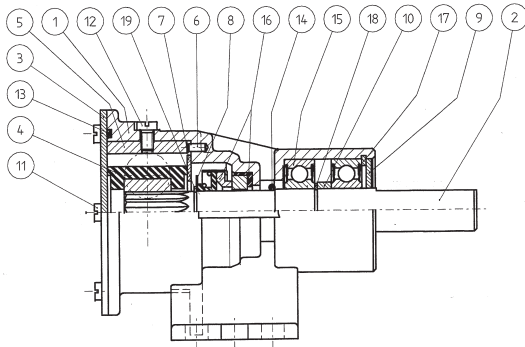

F5B-8

Pos	Nos	Description	10-24571-13	10-24571-14	10-24571-15	10-24571-52	Lipseal
			10-24571-01	10-24571-02	10-24571-03	10-24571-51	Mech. seal
1	1	Body	01-24573-1	01-24573-1	01-24573-1	01-24573-2	
2	1	Shaft	01-46744	01-46744	01-46744	01-46746	
3	1	Endcover	01-46747-2	01-46747-2	01-46747-2	01-46747-2	
4	1	Impeller	09-1027B	09-1027B-9	09-1027B	09-1027B	
5	1	Cam	01-42397	01-42397	01-45014	01-42397	
6	1	Pin	01-42400	01-42400	01-42400	01-42400	
7	1	Wearplate	01-42399-2	01-42399-2	01-42399-2	01-42399-2	
8	1	Washer					
8	1	Washer	01-45680	01-45680	01-45680	01-45680	
9	1	Washer	01-45047	01-45047	01-45047	01-45047	
10	1	Spacer	01-46009	01-46009	01-46009	01-46009	
11	6	Screw	0.0279.300	0.0279.300	0.0279.300	0.0279.300	
12	1	Screw	01-46794-05	01-46794-05	0.0279.032	01-46794-05	
13	1	O-ring	0.2173.475	0.2173.475	0.2173.475	0.2173.475	
14	1	O-ring	0.2173.402	0.2173.402	0.2173.402	0.2173.402	
15	2	Ball bearing	0.3431.742	0.3431.742	0.3431.742	0.3431.742	
16	1	Lipseal	0.2233.012	0.2233.012	0.2233.012	0.2233.012	
16	1	Mech. seal	0.2247.022	0.2247.022	0.2247.022	0.2247.022	
17	1	Retaining ring	0.0371.040	0.0371.040	0.0371.040	0.0371.040	
18	1	Retaining ring	0.0370.017	0.0370.017	0.0370.017	0.0370.017	
19	1	Retaining ring					
19	1	Retaining ring	0.0370.516	0.0370.516	0.0370.516	0.0370.516	

Spareparts kit:

4,11,13 & 16	09-45585	09-45586	09-45585	09-45585	Lipseal
4,11,13 & 16	09-46843	09-46844	09-46843	09-46843	Mech. seal

Parts list

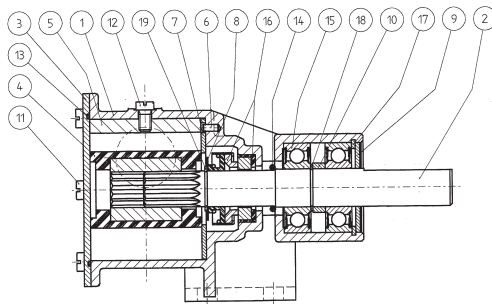

F7B-8

Pos	Nos	Benämning	10-24572-13	10-24572-52	Lipseal
			10-24572-01	10-24572-51	Mech. seal
1	1	Body	01-24574-3	01-24574-4	
2	1	Shaft	01-46744	01-46746	
3	1	Endcover	01-46648-3	01-46648-3	
4	1	Impeller	09-1028BT-1	09-1028BT-1	
5	1	Cam	01-42679	01-42679	
6	1	Pin	01-42400	01-42400	
7	1	Wearplate	01-46798-2	01-46798-2	
8	1	Washer			
8	1	Washer	01-45680	01-45680	
9	1	Washer	01-45047	01-45047	
10	1	Spacer	01-46009	01-46009	
11	6	Screw	0.0279.301	0.0279.301	
12	1	Screw	01-46794-01	01-46794-01	
13	1	O-ring	0.2172.012	0.2172.012	
14	1	O-ring	0.2173.402	0.2173.402	
15	2	Ball bearing	0.3431.742	0.3431.742	
16	1	Lipseal	0.2233.012	0.2233.012	
16	1	Mech. seal	0.2247.022	0.2247.022	
17	1	Retaining ring	0.0371.040	0.0371.040	
18	1	Retaining ring	0.0370.017	0.0370.017	
19	1	Retaining ring			
19	1	Retaining ring	0.0370.516	0.0370.516	

Spareparts kit:

4,11,13 & 16	09-47426	09-47426	Lipseal
4,11,13 & 16	09-47427	09-47427	Mech. seal

Parts list

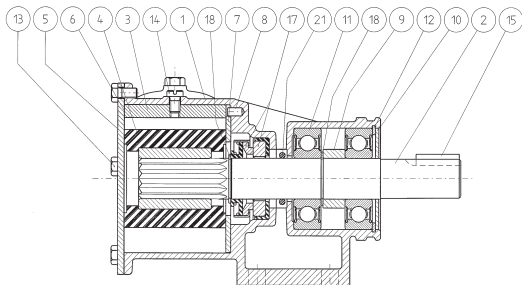

F8B-8 F8B-8007 F8B-8007 F8B-8007

Pos	Nos	Description	10-13021-1	10-13021-9	10-13021-95	10-13021-96
1	1	Body	01-13164-1	01-13164-2	01-13164-3	01-13164-4
2	1	Shaft	01-35132	01-35132	01-35746	01-35746
3	1	Cam	01-42680	01-42680	01-42680	01-42680
4	1	Impeller	09-819B	09-819B	09-819B	09-819B
5	1	Endcover	01-42422-1	01-42422-1	01-42422-1	01-42422-1
6	1	Gasket	01-42424	01-42424	01-42424	01-42424
7	1	Wear plate	01-42423	01-42423	01-42423	01-42423
8	1	Pin	01-42426	01-42426	01-42426	01-42426
9	1	Spacer	01-45374	01-45374	01-45374	01-45374
10	1	Washer	01-45380	01-45380	01-45380	01-45380
11	2	Ball bearing	0.3431.780	0.3431.780	0.3431.780	0.3431.780
12	1	Retaining ring	0.0371.062	0.0371.062	0.0371.062	0.0371.062
13	5	Screw	0.0138.134	0.0138.134	0.0138.134	0.0138.134
14	1	Screw	01-46794-02	01-46794-02	01-46794-02	01-46794-02
15	1	Key	0.0502.231	0.0502.231	-	-
17	1	Mech. seal	0.2247.008	0.2247.008	0.2247.008	0.2247.008
18	2	Lipseal	0.0370.525	0.0370.525	0.0370.525	0.0370.525
21	1	O-ring	0.2172.573	0.2172.573	0.2172.573	0.2172.573

Spareparts kit:

4,6,13,17 & 18 09-45575 09-45575 09-45575 09-45575

Selbstansaugende flexible Impellerpumpe aus Bronze, mit Lagerfuss

Anwendungsbeispiele

- *Für den Marinesektor*
Kühlwasserpumpe für Motoren, Lenzpumpe, Spülpumpe, Entleerung von Fäkalientanks.
- *Für die Industrie*
Förder- und Umwälzpumpe, Entleerung von Schlamm- und Abflussschächten, Pumpen von verunreinigten Flüssigkeiten mit festen Partikeln.

Technische Beschreibung

Gehäuse:	Bronze
Impeller:	Neoprene, EPDM oder Nitrile
Welle:	Edelstahl, gelagert mit zwei dauergeschmierten Kugellagern
Dichtung:	Lippendichtung oder Gleitringdichtung
Kamm:	Voll oder reduzierter Kamm
Anschluss:	Siehe "Modellvarianten", Seite 18

Druck und Leistungsdaten

Siehe Seite 45-47.

Bedienungsanleitungen

Siehe Esatzteilliste Seite 19-23

Demontage

1. Den Deckel und den O-Ring entfernen.
2. Impeller mit Hilfe von zwei Schraubenziehern herausdrücken.
3. Nach Ausbau des Kamms Dichtungsreste vom Pumpengehäuse und Kamm entfernen. Die Verschleißplatte entfernen.
4. Die Lippendichtung oder die Gleitringdichtung entfernen.
5. Die Scheibe (Pos. 9) entfernen, indem ein Schraubendreher durch den Schlitz eingesteckt und damit die Scheibe herausgedrückt wird.

6. Sicherungsring für das Lagerpaket abnehmen.
7. Welle und Kugellager auspressen durch Druck auf die Welle von der Impellerseite her.
8. Die Kugellager/den Sicherungsring und das Distanzstück entfernen. Bei F35B-8, F4B-8 und F8B-8 die Kugellager nicht über die Dichtfläche drücken.
9. Den O-Ring von der Welle entfernen.

Montage

1. Die Kugellager/den Sicherungsring und das Distanzstück anbringen. Bei F35B-8, F4B-8 und F8B-8 die Kugellager nicht über die Dichtfläche drücken.
2. Den O-Ring an die Welle anbringen (nicht bei F8B-8).
3. Welle mit Kugellager in das Pumpengehäuse pressen, Sicherungsring und Scheibe (Pos 9 für F35B-8 - F7B-8 und Pos 10 für F8B-8) montieren. Bei F8B-8 den O-ring, Pos 21, anbringen .
4. O-ring und Lippendichtung oder Gleitringdichtung einsetzen. Lippendichtung mit Öffnung zur Impellerseite hin. Die Verschleißplatte anbringen (Pos. 18).
5. Kamm festschrauben. Auf Kamm und Schraube zuerst etwas Dichtungsmittel auftragen.
6. Impeller einfetten (mit JP Impeller Lubricant) und in Drehrichtung des Impellers montieren.
7. Den O-Ring vor dem Anbringen des Deckels einsetzen.

Entsorgung/Recycling

Nach Lebensdauerende entsorgen Sie die Pumpe nach den örtlichen Vorschriften. Nach Möglichkeit demontieren Sie Teile der Pumpe um sie dem Recycling-Process zuzuführen.

Modellvarianten

F35B-8 Pumpe typ	Artikel Nr. Lippendichtung	Artikel Nr. Gleitringdichtung	Impeller	Kamm	Pumpengehäuse	Anschluss
F35B-8	10-24569-13	10-24569-01	Neopren	1	01-35881-1	ISO7/1-Rp3/8
F35B-802	10-24569-15	10-24569-03	Neopren	1/2	01-35881-1	ISO7/1-Rp3/8
F35B-8007	10-24569-52	10-24569-51	Neopren	1	01-35881-2	3/8-18NPTF
F35B-8027	10-24569-21	10-24569-09	Neopren	1/2	01-35881-2	3/8-18NPTF

F4B-8 Pumpe typ	Artikel Nr. Lippendichtung	Artikel Nr. Gleitringdichtung	Impeller	Kamm	Pumpengehäuse	Anschluss
F4B-8	10-24570-13	10-24570-01	Neopren	1	01-35882-1	ISO7/1-Rp3/8
F4B-89	10-24570-14	10-24570-02	Nitril	1	01-35882-1	ISO7/1-Rp3/8
F4B-8007	10-24570-19	10-24570-07	Neopren	1	01-35882-2	3/8-18NPTF
F4B-8007	10-24570-52	10-24570-51	Neopren	1	01-35882-2	3/8-18NPTF

F5B-8 Pumpe typ	Artikel Nr. Lippendichtung	Artikel Nr. Gleitringdichtung	Impeller	Kamm	Pumpengehäuse	Anschluss
F5B-8	10-24571-13	10-24571-01	Neopren	1	01-24573-1	ISO7/1-Rp3/4
F5B-89	10-24571-14	10-24571-02	Nitril	1	01-24573-1	ISO7/1-Rp3/4
F5B-802	10-24571-15	10-24571-03	Neopren	1/2	01-24573-1	ISO7/1-Rp3/4
F5B-8007	10-24571-52	10-24571-51	Neopren	1	01-24573-2	3/4-14NPTF

F7B-8 Pumpe typ	Artikel Nr. Lippendichtung	Artikel Nr. Gleitringdichtung	Impeller	Kamm	Pumpengehäuse	Anschluss
F7B-8	10-24572-13	10-24572-01	EPDM	1	01-24574-3	ISO7/1-Rp1
F7B-8007	10-24572-52	10-24572-51	EPDM	1	01-24574-4	1-11 1/2NPTF

F8B-8 Pumpe typ	Artikel Nr. Lippendichtung	Artikel Nr. Gleitringdichtung	Impeller	Kamm	Pumpengehäuse	Anschluss
F8B-8		10-13021-1	Neopren	1	01-13164-1	ISO7/1-Rp11/2
F8B-8007		10-13021-9	Neopren	1	01-13164-2	11/2-111/2NPTF
F8B-8007		10-13021-95	Neopren	1	01-13164-3	11/4-111/2NPTF
F8B-8007		10-13021-96	Neopren	1	01-13164-4	11/2-111/2NPTF

Ersatzteilliste

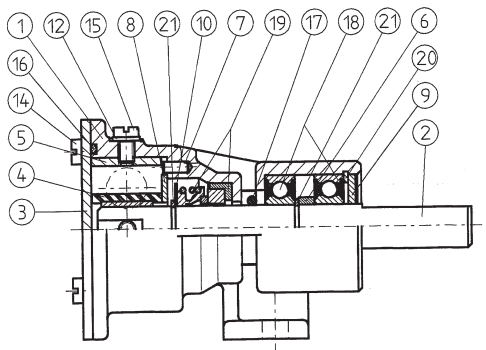

F35B-8

Pos	Nos	Bezeichnung	10-24569-13	10-24569-15	10-24569-52	10-24569-21	Lippendichtung
			10-24569-01	10-24569-03	10-24569-51	10-24569-09	Gleitringdichtung
1	1	Pumpengehäuse	01-35881-1	01-35881-1	01-35881-2	01-35881-2	
2	1	Welle	01-46735-1	01-46735-1	01-46740	01-46735-1	
3	1	Deckel	01-46739-2	01-46739-2	01-46739-2	01-46739-2	
4	1	Impeller	09-808B	09-808B	09-808B	09-808B	
5	1	Kamm	01-42910	01-42415	01-42910	01-42415	
6	1	Distanzring	01-45542	01-45542	01-45542	01-45542	
7	1	Stift	01-42400	01-42400	01-42400	01-42400	
8	1	Schleissplatte	01-46676	01-46676	01-46676	01-46676	
9	1	Scheibe	01-45049	01-45049	01-45049	01-45049	
10	1	Scheibe					
10	1	Scheibe	01-45659	01-45659	01-45659	01-45659	
12	1	Scheibe	01-46790-01	01-46790-01	01-46790-01	01-46790-01	
14	4	Schraube	0.0279.300	0.0279.300	0.0279.300	0.0279.300	
15	1	Schraube	01-46974-03	01-46794-10	01-46794-03	01-46794-10	
16	1	O-ring	0.2173.440	0.2173.440	0.2173.440	0.2173.440	
17	1	O-ring	0.2173.432	0.2173.432	0.2173.432	0.2173.432	
18	2	Kugellager	0.3431.748	0.3431.748	0.3431.748	0.3431.748	
19	1	Lippendichtung	0.2233.010	0.2233.010	0.2233.010	0.2233.010	
19	1	Gleitringdichtung	0.2247.021	0.2247.021	0.2247.021	0.2247.021	
20	1	Sicherungsring	0.0371.028	0.0371.028	0.0371.028	0.0371.028	
21	1	Sicherungsring	0.0370.012	0.0370.012	0.0370.012	0.0370.012	
21	2	Sicherungsring	0.0370.012	0.0370.012	0.0370.012	0.0370.012	

Servicesatz:

4,14,16&19	09-45589	09-45589	09-45589	09-45589	Lippendichtung
4,14,16&19	09-46840	09-46840	09-46840	09-46840	Gleitringdichtung

Ersatzteilliste

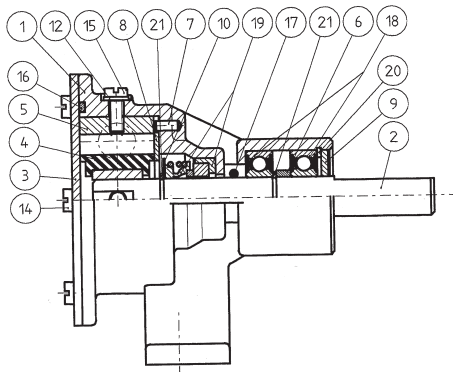

F4B-8

Pos	Nos	Bezeichnung	10-24570-13	10-24570-14	10-24570-19	10-24570-52	Lippendichtung
			10-24570-01	10-24570-02	10-24570-07	10-24570-51	Gleitringdichtung
1	1	Pumpengehäuse	01-35882-1	01-35882-1	01-35882-2	01-35882-2	
2	1	Welle	01-46735-1	01-46735-1	01-46735-1	01-46740	
3	1	Deckel	01-46007-2	01-46007-2	01-46007-2	01-46007-2	
4	1	Impeller	09-810B	09-810B-9	09-810B	09-810B	
5	1	Kamm	01-42389	01-42389	01-42389	01-42389	
6	1	Distanzring	01-45542	01-45542	01-45542	01-45542	
7	1	Stift	01-42400	01-42400	01-42400	01-42400	
8	1	Schleissplatte	01-46737-2	01-46737-2	01-46737-2	01-46737-2	
9	1	Scheibe	01-45049	01-45049	01-45049	01-45049	
10	1	Scheibe					
10	1	Scheibe	01-45659	01-45659	01-45659	01-45659	
12	1	Scheibe	01-46790-01	01-46790-01	01-46790-01	01-46790-01	
14	6	Schraube	0.0279.300	0.0279.300	0.0279.300	0.0279.300	
15	1	Schraube	01-46794-04	01-46794-04	01-46794-04	01-46794-04	
16	1	O-ring	0.2173.476	0.2173.476	0.2173.476	0.2173.476	
17	1	O-ring	0.2173.432	0.2173.432	0.2173.432	0.2173.432	
18	2	Kugellager	0.3431.748	0.3431.748	0.3431.748	0.3431.748	
19	1	Lippendichtung	0.2233.010	0.2233.010	0.2233.010	0.2233.010	
19	1	Gleitringdichtung	0.2247.021	0.2247.021	0.2247.021	0.2247.021	
20	1	Sicherungsring	0.0371.028	0.0371.028	0.0371.028	0.0371.028	
21	1	Sicherungsring	0.0370.012	0.0370.012	0.0370.012	0.0370.012	
21	2	Sicherungsring	0.0370.012	0.0370.012	0.0370.012	0.0370.012	

Servicesatz:

4,14,16 & 19	09-45587	09-45588	09-45587	09-45587	Lippendichtung
4,14,16 & 19	09-46841	09-46842	09-46841	09-46841	Gleitringdichtung

Ersatzteilliste

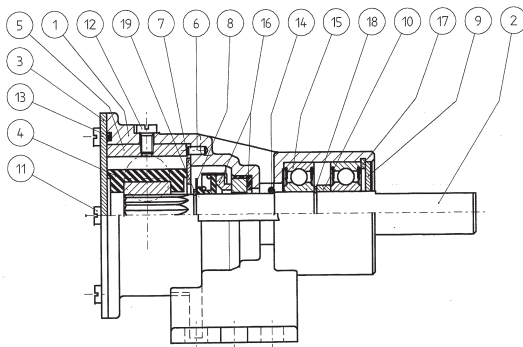

F5B-8

Pos	Nos	Bezeichnung	10-24571-13	10-24571-14	10-24571-15	10-24571-52	Lippendichtung
			10-24571-01	10-24571-02	10-24571-03	10-24571-51	Gleitringdichtung
1	1	Pumpengehäuse	01-24573-1	01-24573-1	01-24573-1	01-24573-2	
2	1	Welle	01-46744	01-46744	01-46744	01-46746	
3	1	Deckel	01-46747-2	01-46747-2	01-46747-2	01-46747-2	
4	1	Impeller	09-1027B	09-1027B-9	09-1027B	09-1027B	
5	1	Kamm	01-42397	01-42397	01-45014	01-42397	
6	1	Stift	01-42400	01-42400	01-42400	01-42400	
7	1	Schleissplatte	01-42399-2	01-42399-2	01-42399-2	01-42399-2	
8	1	Scheibe					
8	1	Scheibe	01-45680	01-45680	01-45680	01-45680	
9	1	Scheibe	01-45047	01-45047	01-45047	01-45047	
10	1	Distanzring	01-46009	01-46009	01-46009	01-46009	
11	6	Schraube	0.0279.300	0.0279.300	0.0279.300	0.0279.300	
12	1	Schraube	01-46794-05	01-46794-05	0.0279.032	01-46794-05	
13	1	O-ring	0.2173.475	0.2173.475	0.2173.475	0.2173.475	
14	1	O-ring	0.2173.402	0.2173.402	0.2173.402	0.2173.402	
15	2	Kugellager	0.3431.742	0.3431.742	0.3431.742	0.3431.742	
16	1	Lippendichtung	0.2233.012	0.2233.012	0.2233.012	0.2233.012	
16	1	Gleitringdichtung	0.2247.022	0.2247.022	0.2247.022	0.2247.022	
17	1	Sicherungsring	0.0371.040	0.0371.040	0.0371.040	0.0371.040	
18	1	Sicherungsring	0.0370.017	0.0370.017	0.0370.017	0.0370.017	
19	1	Sicherungsring					
19	1	Sicherungsring	0.0370.516	0.0370.516	0.0370.516	0.0370.516	

Servicesatz:

4,11,13 & 16	09-45585	09-45586	09-45585	09-45585	Lippendichtung
4,11,13 & 16	09-46843	09-46844	09-46843	09-46843	Gleitringdichtung

Ersatzteilliste

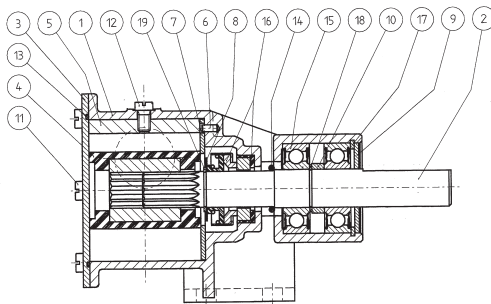

F7B-8

Pos	Nos	Bezeichnung	10-24572-13	10-24572-52 Lippendichtung
			10-24572-01	10-24572-51 Gleitringdichtung
1	1	Pumpengehäuse	01-24574-3	01-24574-4
2	1	Welle	01-46744	01-46746
3	1	Deckel	01-46648-3	01-46648-3
4	1	Impeller	09-1028BT-1	09-1028BT-1
5	1	Kamm	01-42679	01-42679
6	1	Stift	01-42400	01-42400
7	1	Schleissplatte	01-46798-2	01-46798-2
8	1	Scheibe		
8	1	Scheibe	01-45680	01-45680
9	1	Scheibe	01-45047	01-45047
10	1	Distanzring	01-46009	01-46009
11	6	Schraube	0.0279.301	0.0279.301
12	1	Schraube	01-46794-01	01-46794-01
13	1	O-ring	0.2172.012	0.2172.012
14	1	O-ring	0.2173.402	0.2173.402
15	2	Kugellager	0.3431.742	0.3431.742
16	1	Lippendichtung	0.2233.012	0.2233.012
16	1	Gleitringdichtung	0.2247.022	0.2247.022
17	1	Sicherungsring	0.0371.040	0.0371.040
18	1	Sicherungsring	0.0370.017	0.0370.017
19	1	Sicherungsring		
19	1	Sicherungsring	0.0370.516	0.0370.516

Servicesatz:

4,11,13 & 16	09-47426	09-47426	Lippendichtung
4,11,13 & 16	09-47427	09-47427	Gleitringdichtung

Ersatzteilliste

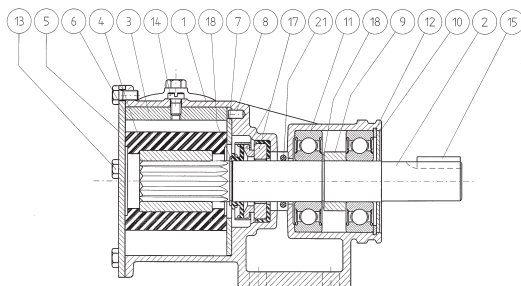

Pos	Nos	Bezeichnung	F8B-8	F8B-8007	F8B-8007	F8B-8007
			10-13021-1	10-13021-9	10-13021-95	10-13021-96
1	1	Pumpengehäuse	01-13164-1	01-13164-2	01-13164-3	01-13164-4
2	1	Welle	01-35132	01-35132	01-35746	01-35746
3	1	Kamm	01-42680	01-42680	01-42680	01-42680
4	1	Impeller	09-819B	09-819B	09-819B	09-819B
5	1	Deckel	01-42422-1	01-42422-1	01-42422-1	01-42422-1
6	1	Dichtung	01-42424	01-42424	01-42424	01-42424
7	1	Schleissplatte	01-42423	01-42423	01-42423	01-42423
8	1	Stift	01-42426	01-42426	01-42426	01-42426
9	1	Distanzring	01-45374	01-45374	01-45374	01-45374
10	1	Scheibe	01-45380	01-45380	01-45380	01-45380
11	2	Kugellager	0.3431.780	0.3431.780	0.3431.780	0.3431.780
12	1	Sicherungsring	0.0371.062	0.0371.062	0.0371.062	0.0371.062
13	5	Schraube	0.0138.134	0.0138.134	0.0138.134	0.0138.134
14	1	Schraube	01-46794-02	01-46794-02	01-46794-02	01-46794-02
15	1	Keil	0.0502.231	0.0502.231	-	-
17	1	Gleitringdichtung	0.2247.008	0.2247.008	0.2247.008	0.2247.008
18	2	Sicherungsring	0.0370.525	0.0370.525	0.0370.525	0.0370.525
21	1	O-ring	0.2172.573	0.2172.573	0.2172.573	0.2172.573
Servicesatz:						
		4,6,13,17 & 18	09-45575	09-45575	09-45575	09-45575

Pompe auto-amorçante en bronze à rotor souple, sur embase

Types d'applications

- *Marine*
Pompe de câble, lavage au jet pour ponts de bateaux, pompe de refroidissement pour moteurs, remplissage de réservoirs.
- *Industrie*
Circulation et transfert de liquide, remplissage de réservoirs et vidange de bacs, manutention de solides en suspensions.

Spécifications

Corps:	Bronze
Rotor:	Néoprène, EPDM ou nitrile
Arbre:	Acier inoxydable L'arbre est monté sur deux roulements lubrifiés "à vie"
Joint:	Joint à lèvres ou joint mécanique
Came:	1/1 ou réduite
Orifices:	Voir "Spécifications du modèle", page 25

Pressions et débits

Voir page 45-47

Instructions d'entretien

Voir liste des pièces page 26-30

Démontage

1. Déposez la flasque latérale et le joint torique.
2. Arrachez le rotor en utilisant deux tournevis ou autre objet adéquat.
3. Déposez la came et éliminez toute trace de mastic d'étanchéité sur la came et dans le corps de pompe. Déposez la plaque d'usure.
4. Déposez le joint à lèvres ou la garniture mécanique.
5. Déposez la rondelle (pos 9 pour les modèles F35B-8 et F7B-8 et pos 10

pour F8B-8) en faisant levier à l'aide d'un tournevis inséré dans la rainure.

6. Enlever le circlips qui retient les roulements.
7. Déposer l'arbre avec les roulements en faisant pression sur l'arbre du côté du rotor.
8. Déposez les roulements ou le circlips ainsi que l'entretoise. Sur les modèles F35B-8, F4B-8 et F8B-8, veillez à ce que les roulements ne viennent pas en contact avec la surface d'étanchéité.
9. Otez le joint torique de l'arbre.

Montage

1. Remontez les roulement à billes ou le circlips ainsi que l'entretoise sur l'arbre. Sur les modèles F35B-8, F4B-8 et F8B-8, veillez à ce que les roulements ne viennent pas en contact avec la surface d'étanchéité.
2. Posez le joint torique sur l'arbre (ne concerne pas le modèle F8B-8).
3. Remplacez l'arbre équipé des roulements à billes dans le corps de pompe ; posez le circlips et la rondelle (pos 9 pour les modèles F35B-8 et F7B-8 et pos 10 pour F8B-8). Sur le modèle F8B-8 posez le joint torique pos 21.
4. Posez le joint à lèvres (ressort vers le rotor de pompe) ou la garniture mécanique. Posez la plaque d'usure (18).
5. Fixez la came après l'avoir enduite ainsi que la vis de came, de pâte à joint.
6. Lubrifiez le rotor avec le lubrifiant JP Impeller Lubricant en place en le faisant tourner dans le sens de rotation de la pompe.
7. Posez le joint torique avant de remettre en place la flasque latérale.

Gestion des déchets/recyclage des matériaux

Lorsque le matériel arrivera en fin de vie, veuillez le mettre au rebut en fonction des lois applicables. Lorsque c'est possible, veuillez démonter le matériel et recycler les pièces pouvant l'être

Spécifications du modèle

F35B-8 Modèle	Référence. Joint à lèvres	Référence. Joint mécanique	Impeller	Came	Corps	Orifice
F35B-8	10-24569-13	10-24569-01	Neopren	1	01-35881-1	ISO7/1-Rp3/8
F35B-802	10-24569-15	10-24569-03	Neopren	1/2	01-35881-1	ISO7/1-Rp3/8
F35B-8007	10-24569-52	10-24569-51	Neopren	1	01-35881-2	3/8-18NPTF
F35B-8027	10-24569-21	10-24569-09	Neopren	1/2	01-35881-2	3/8-18NPTF

F4B-8 Modèle	Référence. Joint à lèvres	Référence. Joint mécanique	Impeller	Came	Corps	Orifice
F4B-8	10-24570-13	10-24570-01	Neopren	1	01-35882-1	ISO7/1-Rp3/8
F4B-89	10-24570-14	10-24570-02	Nitril	1	01-35882-1	ISO7/1-Rp3/8
F4B-8007	10-24570-19	10-24570-07	Neopren	1	01-35882-2	3/8-18NPTF
F4B-8007	10-24570-52	10-24570-51	Neopren	1	01-35882-2	3/8-18NPTF

F5B-8 Modèle	Référence. Joint à lèvres	Référence. Joint mécanique	Impeller	Came	Corps	Orifice
F5B-8	10-24571-13	10-24571-01	Neopren	1	01-24573-1	ISO7/1-Rp3/4
F5B-89	10-24571-14	10-24571-02	Nitril	1	01-24573-1	ISO7/1-Rp3/4
F5B-802	10-24571-15	10-24571-03	Neopren	1/2	01-24573-1	ISO7/1-Rp3/4
F5B-8007	10-24571-52	10-24571-51	Neopren	1	01-24573-2	3/4-14NPTF

F7B-8 Modèle	Référence. Joint à lèvres	Référence. Joint mécanique	Impeller	Came	Corps	Orifice
F7B-8	10-24572-13	10-24572-01	EPDM	1	01-24574-3	ISO7/1-Rp1
F7B-8007	10-24572-52	10-24572-51	EPDM	1	01-24574-4	1-11 1/2NPTF

F8B-8 Modèle	Référence. Joint à lèvres	Référence. Joint mécanique	Impeller	Came	Corps	Orifice
F8B-8		10-13021-1	Neopren	1	01-13164-1	ISO7/1-Rp11/2
F8B-8007		10-13021-9	Neopren	1	01-13164-2	11/2-111/2NPTF
F8B-8007		10-13021-95	Neopren	1	01-13164-3	11/4-111/2NPTF
F8B-8007		10-13021-96	Neopren	1	01-13164-4	11/2-111/2NPTF

Liste des pièces

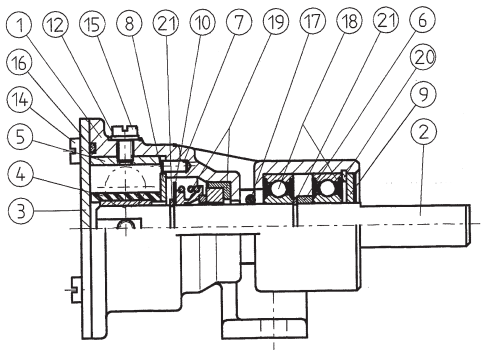

F35B-8

Rep	Nos	Description	10-24569-13	10-24569-15	10-24569-52	10-24569-21	Joint à lèvres
			10-24569-01	10-24569-03	10-24569-51	10-24569-09	Joint mécanique
1	1	Corps	01-35881-1	01-35881-1	01-35881-2	01-35881-2	
2	1	Arbre	01-46735-1	01-46735-1	01-46740	01-46735-1	
3	1	Couvercle	01-46739-2	01-46739-2	01-46739-2	01-46739-2	
4	1	Rotor	09-808B	09-808B	09-808B	09-808B	
5	1	Came	01-42910	01-42415	01-42910	01-42415	
6	1	Entretoise	01-45542	01-45542	01-45542	01-45542	
7	1	Ergot	01-42400	01-42400	01-42400	01-42400	
8	1	Plaque d'usure	01-46676	01-46676	01-46676	01-46676	
9	1	Rondelle	01-45049	01-45049	01-45049	01-45049	
10	1	Rondelle					
10	1	Rondelle	01-45659	01-45659	01-45659	01-45659	
12	1	Rondelle	01-46790-01	01-46790-01	01-46790-01	01-46790-01	
14	4	Vis	0.0279.300	0.0279.300	0.0279.300	0.0279.300	
15	1	Vis	01-46974-03	01-46794-10	01-46794-03	01-46794-10	
16	1	Joint O-ring	0.2173.440	0.2173.440	0.2173.440	0.2173.440	
17	1	Joint O-ring	0.2173.432	0.2173.432	0.2173.432	0.2173.432	
18	2	Roulements à billes	0.3431.748	0.3431.748	0.3431.748	0.3431.748	
19	1	Joint à lèvres	0.2233.010	0.2233.010	0.2233.010	0.2233.010	
19	1	Joint mécanique	0.2247.021	0.2247.021	0.2247.021	0.2247.021	
20	1	Clips	0.0371.028	0.0371.028	0.0371.028	0.0371.028	
21	1	Clips	0.0370.012	0.0370.012	0.0370.012	0.0370.012	
21	2	Clips	0.0370.012	0.0370.012	0.0370.012	0.0370.012	

Kit de réparation:

4,14,16&19	09-45589	09-45589	09-45589	09-45589	Joint à lèvres
4,14,16&19	09-46840	09-46840	09-46840	09-46840	Joint mécanique

Liste des pièces

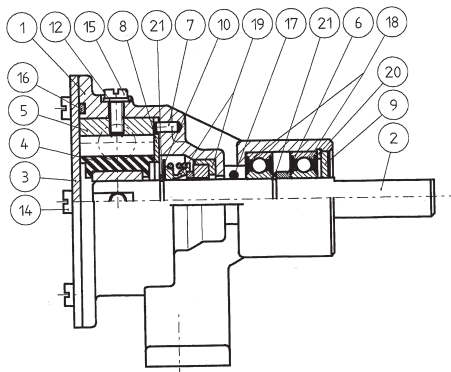

F4B-8

Rep	Nos	Description	10-24570-13	10-24570-14	10-24570-19	10-24570-52	Joint à lèvres
			10-24570-01	10-24570-02	10-24570-07	10-24570-51	Joint mécanique
1	1	Corps	01-35882-1	01-35882-1	01-35882-2	01-35882-2	
2	1	Arbre	01-46735-1	01-46735-1	01-46735-1	01-46740	
3	1	Couvercle	01-46007-2	01-46007-2	01-46007-2	01-46007-2	
4	1	Rotor	09-810B	09-810B-9	09-810B	09-810B	
5	1	Came	01-42389	01-42389	01-42389	01-42389	
6	1	Entrtoise	01-45542	01-45542	01-45542	01-45542	
7	1	Ergot	01-42400	01-42400	01-42400	01-42400	
8	1	Plaque d'usure	01-46737-2	01-46737-2	01-46737-2	01-46737-2	
9	1	Rondelle	01-45049	01-45049	01-45049	01-45049	
10	1	Rondelle					
10	1	Rondelle	01-45659	01-45659	01-45659	01-45659	
12	1	Rondelle	01-46790-01	01-46790-01	01-46790-01	01-46790-01	
14	6	Vis	0.0279.300	0.0279.300	0.0279.300	0.0279.300	
15	1	Vis	01-46794-04	01-46794-04	01-46794-04	01-46794-04	
16	1	Joint O-ring	0.2173.476	0.2173.476	0.2173.476	0.2173.476	
17	1	Joint O-ring	0.2173.432	0.2173.432	0.2173.432	0.2173.432	
18	2	Roulements à billes	0.3431.748	0.3431.748	0.3431.748	0.3431.748	
19	1	Joint à lèvres	0.2233.010	0.2233.010	0.2233.010	0.2233.010	
19	1	Joint mécanique	0.2247.021	0.2247.021	0.2247.021	0.2247.021	
20	1	Clips	0.0371.028	0.0371.028	0.0371.028	0.0371.028	
21	1	Clips	0.0370.012	0.0370.012	0.0370.012	0.0370.012	
21	2	Clips	0.0370.012	0.0370.012	0.0370.012	0.0370.012	

Kit de réparation:

4,14,16 & 19	09-45587	09-45588	09-45587	09-45587	Joint à lèvres
4,14,16 & 19	09-46841	09-46842	09-46841	09-46841	Joint mécanique

Liste des pièces

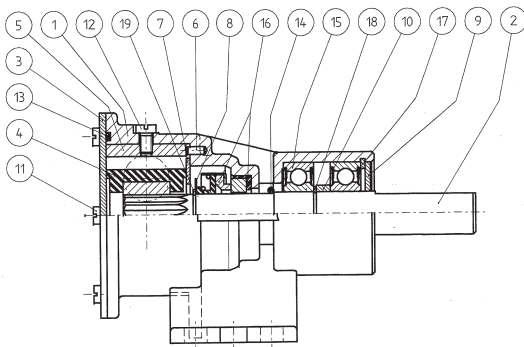

F5B-8

Rep	Nos	Description	10-24571-13	10-24571-14	10-24571-15	10-24571-52	Joint à lèvres
			10-24571-01	10-24571-02	10-24571-03	10-24571-51	Joint mécanique
1	1	Corps	01-24573-1	01-24573-1	01-24573-1	01-24573-2	
2	1	Arbre	01-46744	01-46744	01-46744	01-46746	
3	1	Couvercle	01-46747-2	01-46747-2	01-46747-2	01-46747-2	
4	1	Rotor	09-1027B	09-1027B-9	09-1027B	09-1027B	
5	1	Came	01-42397	01-42397	01-45014	01-42397	
6	1	Ergot	01-42400	01-42400	01-42400	01-42400	
7	1	Plaque d'usure	01-42399-2	01-42399-2	01-42399-2	01-42399-2	
8	1	Rondelle					
8	1	Rondelle	01-45680	01-45680	01-45680	01-45680	
9	1	Rondelle	01-45047	01-45047	01-45047	01-45047	
10	1	Entretoise	01-46009	01-46009	01-46009	01-46009	
11	6	Vis	0.0279.300	0.0279.300	0.0279.300	0.0279.300	
12	1	Vis	01-46794-05	01-46794-05	0.0279.032	01-46794-05	
13	1	Joint O-ring	0.2173.475	0.2173.475	0.2173.475	0.2173.475	
14	1	Joint O-ring	0.2173.402	0.2173.402	0.2173.402	0.2173.402	
15	2	Roulements à billes	0.3431.742	0.3431.742	0.3431.742	0.3431.742	
16	1	Joint à lèvres	0.2233.012	0.2233.012	0.2233.012	0.2233.012	
16	1	Joint mécanique	0.2247.022	0.2247.022	0.2247.022	0.2247.022	
17	1	Clips	0.0371.040	0.0371.040	0.0371.040	0.0371.040	
18	1	Clips	0.0370.017	0.0370.017	0.0370.017	0.0370.017	
19	1	Clips					
19	1	Clips	0.0370.516	0.0370.516	0.0370.516	0.0370.516	

Kit de réparation:

4, 11, 13 & 16	09-45585	09-45586	09-45585	09-45585	Joint à lèvres
4, 11, 13 & 16	09-46843	09-46844	09-46843	09-46843	Joint mécanique

Liste des pièces

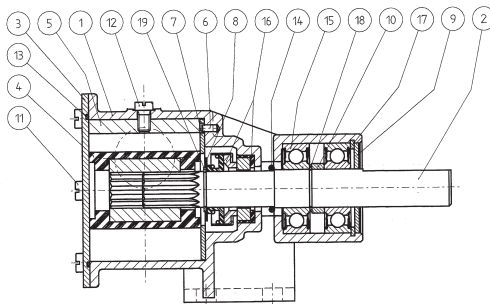

F7B-8

Rep Nos Description

Rep	Nos	Description	10-24572-13	10-24572-52	Joint à lèvres
Rep	Nos	Description	10-24572-01	10-24572-51	Joint mécanique
1	1	Corps	01-24574-3	01-24574-4	
2	1	Arbre	01-46744	01-46746	
3	1	Couvercle	01-46648-3	01-46648-3	
4	1	Rotor	09-1028BT-1	09-1028BT-1	
5	1	Came	01-42679	01-42679	
6	1	Ergot	01-42400	01-42400	
7	1	Plaque d'usure	01-46798-2	01-46798-2	
8	1	Rondelle			
8	1	Rondelle	01-45680	01-45680	
9	1	Rondelle	01-45047	01-45047	
10	1	Entretoise	01-46009	01-46009	
11	6	Vis	0.0279.301	0.0279.301	
12	1	Vis	01-46794-01	01-46794-01	
13	1	Joint O-ring	0.2172.012	0.2172.012	
14	1	Joint O-ring	0.2173.402	0.2173.402	
15	2	Roulements à billes	0.3431.742	0.3431.742	
16	1	Joint à lèvres	0.2233.012	0.2233.012	
16	1	Joint mécanique	0.2247.022	0.2247.022	
17	1	Clips	0.0371.040	0.0371.040	
18	1	Clips	0.0370.017	0.0370.017	
19	1	Clips			
19	1	Clips	0.0370.516	0.0370.516	

Kit de réparation:

4,11,13 & 16	09-47426	09-47426	Joint à lèvres
4,11,13 & 16	09-47427	09-47427	Joint mécanique

Liste des pièces

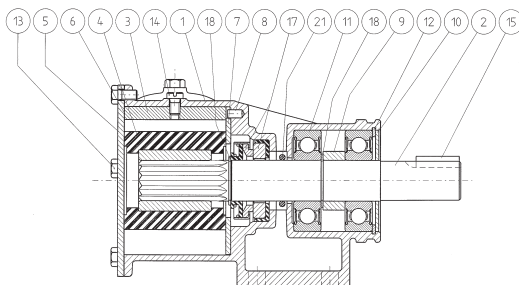

			F8B-8	F8B-8007	F8B-8007	F8B-8007
Rep	Nos	Description	10-13021-1	10-13021-9	10-13021-95	10-13021-96
1	1	Corps	01-13164-1	01-13164-2	01-13164-3	01-13164-4
2	1	Arbre	01-35132	01-35132	01-35746	01-35746
3	1	Came	01-42680	01-42680	01-42680	01-42680
4	1	Rotor	09-819B	09-819B	09-819B	09-819B
5	1	Couvercle	01-42422-1	01-42422-1	01-42422-1	01-42422-1
6	1	Joint	01-42424	01-42424	01-42424	01-42424
7	1	Plaque d'usure	01-42423	01-42423	01-42423	01-42423
8	1	Ergot	01-42426	01-42426	01-42426	01-42426
9	1	Entretoise	01-45374	01-45374	01-45374	01-45374
10	1	Rondelle	01-45380	01-45380	01-45380	01-45380
11	2	Roulements à billes	0.3431.780	0.3431.780	0.3431.780	0.3431.780
12	1	Clips	0.0371.062	0.0371.062	0.0371.062	0.0371.062
13	5	Vis	0.0138.134	0.0138.134	0.0138.134	0.0138.134
14	1	Vis	01-46794-02	01-46794-02	01-46794-02	01-46794-02
15	1	Clavette	0.0502.231	0.0502.231	-	-
17	1	Joint mécanique	0.2247.008	0.2247.008	0.2247.008	0.2247.008
18	2	Clips	0.0370.525	0.0370.525	0.0370.525	0.0370.525
21	1	Joint O-ring	0.2172.573	0.2172.573	0.2172.573	0.2172.573
Kit de réparation:						
		4,6,13,17 & 18	09-45575	09-45575	09-45575	09-45575

Bombas autocebadas de bronce con impulsor flexible, sobre pedestal

Aplicaciones usuales

- *Marítimo*
Refrigeración motor, achique, baldeo, vaciado de tanques.
- *Industria*
Trasiego de líquidos, vaciado de tanques, sumidero drenaje, trasvase de sólidos en suspensión.

Características técnicas

Cuerpo:	Bronce
Impulsor:	Neopreno, EPDM o nitrilo
Eje:	Acero inoxidable con doble cojinete a bolas de engrase permanente
Retén:	Junta de labios o mecánica
Leva:	Completa o reducida
Conexión:	Ver "Modelo", página 32

Caudales y presiones

Ver página 45-47

Instrucciones mantenimiento

Ver lista de piezas página 33-37.

Desmontaje

1. Quite la tapa del extremo y la junta obturadora.
2. Saque el impulsor utilizando dos destornilladores u otros instrumentos adecuados.
3. Desmonte la leva y limpie cualquier resto que pueda quedar y retener la leva dentro del cuerpo de la bomba. Desmonte también la placa de desgaste.
4. Quite la junta de labios o, alternativamente, el retén mecánico y la junta tórica.
5. Quite la arandela (pos. 9 en los modelos F35B-8 - F7B-8 y pos. 10 en el modelo F8B-8) introduciendo un destornillador por la ranura y haciendo palanca sobre la arandela.

6. Quite el anillo de retención de los cojinetes.
7. Desmonte el eje con los cojinetes a bolas, presionando sobre el extremo del eje desde el lado del impulsor.
8. Desmonte los cojinetes a bolas/anillo de retención, y en el modelo F8B-8 también la pieza de separación. En los modelos F35B-8, F4B-8 y F8B-8 no presione los cojinetes a bolas sobre la superficie obturadora.
9. Retire la junta tórica del eje.

Montaje

1. Monte el cojinete de bolas y el aro reten en el eje. En el modelo F35B-8, F4B-8 y F8B-8, no presione el cojinete de bolas contra la superficie del retén.
2. Monte la junta tórica en el eje. No en el modelo F8B-8.
3. Introduzca el eje con el cojinete de bolas dentro del cuerpo, coloque la junta tórica y la arandela (posición 9 para la F35B-8, F7B-8 y posición 10 para la F8B-8). Monte la junta tórica en la posición 21 (solo para la F8B-8)
4. Monte el reten (con el tensor/muelle mirando al impulsor) o alternativamente el retén mecánico, monte también la placa de presión de desgaste (posición 18)
5. Apriete la leva, pero antes de hacerlo aplique un poco de compuesto obturador a la leva y al tornillo para evitar fugas.
6. Lubrique el impulsor con lubricante Johnson y colóquelo con un movimiento giratorio en la dirección de rotación prevista.
7. Coloque la junta obturadora antes de montar la tapa del extremo.

Desguace/Reciclado

Al final de la vida del equipo disponga de este de acuerdo a la ley. Donde sea de aplicación desmonte el equipo y recicle los diferentes materiales.

Modelo

F35B-8 Tipo	Pieza No. Junto de labio	Pieza No. Junto de mecánica Impeller	Leva	Cuerpo	Conexión
F35B-8	10-24569-13	10-24569-01	Neopren	1	01-35881-1 ISO7/1-Rp3/8
F35B-802	10-24569-15	10-24569-03	Neopren	1/2	01-35881-1 ISO7/1-Rp3/8
F35B-8007	10-24569-52	10-24569-51	Neopren	1	01-35881-2 3/8-18NPTF
F35B-8027	10-24569-21	10-24569-09	Neopren	1/2	01-35881-2 3/8-18NPTF

F4B-8 Tipo	Pieza No. Junto de labio	Pieza No. Junto de mecánica Impeller	Leva	Cuerpo	Conexión
F4B-8	10-24570-13	10-24570-01	Neopren	1	01-35882-1 ISO7/1-Rp3/8
F4B-89	10-24570-14	10-24570-02	Nitril	1	01-35882-1 ISO7/1-Rp3/8
F4B-8007	10-24570-19	10-24570-07	Neopren	1	01-35882-2 3/8-18NPTF
F4B-8007	10-24570-52	10-24570-51	Neopren	1	01-35882-2 3/8-18NPTF

F5B-8 Tipo	Pieza No. Junto de labio	Pieza No. Junto de mecánica Impeller	Leva	Cuerpo	Conexión
F5B-8	10-24571-13	10-24571-01	Neopren	1	01-24573-1 ISO7/1-Rp3/4
F5B-89	10-24571-14	10-24571-02	Nitril	1	01-24573-1 ISO7/1-Rp3/4
F5B-802	10-24571-15	10-24571-03	Neopren	1/2	01-24573-1 ISO7/1-Rp3/4
F5B-8007	10-24571-52	10-24571-51	Neopren	1	01-24573-2 3/4-14NPTF

F7B-8 Tipo	Pieza No. Junto de labio	Pieza No. Junto de mecánica Impeller	Leva	Cuerpo	Conexión
F7B-8	10-24572-13	10-24572-01	EPDM	1	01-24574-3 ISO7/1-Rp1
F7B-8007	10-24572-52	10-24572-51	EPDM	1	01-24574-4 1-11 1/2NPTF

F8B-8 Tipo	Pieza No. Junto de labio	Pieza No. Junto de mecánica Impeller	Leva	Cuerpo	Conexión
F8B-8		10-13021-1	Neopren	1	01-13164-1 ISO7/1-Rp11/2
F8B-8007		10-13021-9	Neopren	1	01-13164-2 11/2-111/2NPTF
F8B-8007		10-13021-95	Neopren	1	01-13164-3 11/4-111/2NPTF
F8B-8007		10-13021-96	Neopren	1	01-13164-4 11/2-111/2NPTF

Lista de piezas

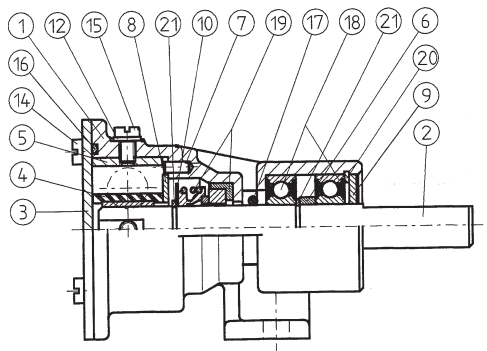

F35B-8

Pos	Nos	Descripción	10-24569-13	10-24569-15	10-24569-52	10-24569-21	Junto de labio
			10-24569-01	10-24569-03	10-24569-51	10-24569-09	Junto de mecánica
1	1	Cuerpo	01-35881-1	01-35881-1	01-35881-2	01-35881-2	
2	1	Eje	01-46735-1	01-46735-1	01-46740	01-46735-1	
3	1	Tapa	01-46739-2	01-46739-2	01-46739-2	01-46739-2	
4	1	Impulsor	09-808B	09-808B	09-808B	09-808B	
5	1	Leva	01-42910	01-42415	01-42910	01-42415	
6	1	Separador	01-45542	01-45542	01-45542	01-45542	
7	1	Cabilla	01-42400	01-42400	01-42400	01-42400	
8	1	Pletina	01-46676	01-46676	01-46676	01-46676	
9	1	Arandela	01-45049	01-45049	01-45049	01-45049	
10	1	Arandela					
10	1	Arandela	01-45659	01-45659	01-45659	01-45659	
12	1	Arandela	01-46790-01	01-46790-01	01-46790-01	01-46790-01	
14	4	Tornillo	0.0279.300	0.0279.300	0.0279.300	0.0279.300	
15	1	Tornillo	01-46974-03	01-46794-10	01-46794-03	01-46794-10	
16	1	Junto aro tórica	0.2173.440	0.2173.440	0.2173.440	0.2173.440	
17	1	Junto aro tórica	0.2173.432	0.2173.432	0.2173.432	0.2173.432	
18	2	Cojinete	0.3431.748	0.3431.748	0.3431.748	0.3431.748	
19	1	Junto de labio	0.2233.010	0.2233.010	0.2233.010	0.2233.010	
19	1	Junto de mecánica	0.2247.021	0.2247.021	0.2247.021	0.2247.021	
20	1	Retén	0.0371.028	0.0371.028	0.0371.028	0.0371.028	
21	1	Retén	0.0370.012	0.0370.012	0.0370.012	0.0370.012	
21	2	Retén	0.0370.012	0.0370.012	0.0370.012	0.0370.012	

Juego recambios:

4, 14, 16 & 19	09-45589	09-45589	09-45589	09-45589	Junto de labio
4, 14, 16 & 19	09-46840	09-46840	09-46840	09-46840	Junto de mecánica

Lista de piezas

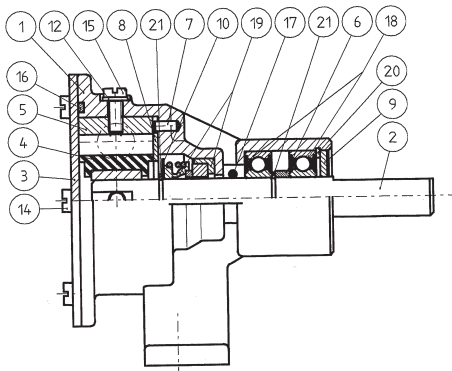

F4B-8

Pos	Nos	Descripción	10-24570-13	10-24570-14	10-24570-19	10-24570-52
			10-24570-01	10-24570-02	10-24570-07	10-24570-51
						Junto de labio
						Junto de mecánica
1	1	Cuerpo	01-35882-1	01-35882-1	01-35882-2	01-35882-2
2	1	Eje	01-46735-1	01-46735-1	01-46735-1	01-46740
3	1	Tapa	01-46007-2	01-46007-2	01-46007-2	01-46007-2
4	1	Impulsor	09-810B	09-810B-9	09-810B	09-810B
5	1	Leva	01-42389	01-42389	01-42389	01-42389
6	1	Separador	01-45542	01-45542	01-45542	01-45542
7	1	Cabilla	01-42400	01-42400	01-42400	01-42400
8	1	Pletina	01-46737-2	01-46737-2	01-46737-2	01-46737-2
9	1	Arandela	01-45049	01-45049	01-45049	01-45049
10	1	Arandela				
10	1	Arandela	01-45659	01-45659	01-45659	01-45659
12	1	Arandela	01-46790-01	01-46790-01	01-46790-01	01-46790-01
14	6	Tornillo	0.0279.300	0.0279.300	0.0279.300	0.0279.300
15	1	Tornillo	01-46794-04	01-46794-04	01-46794-04	01-46794-04
16	1	Junto aro tórica	0.2173.476	0.2173.476	0.2173.476	0.2173.476
17	1	Junto aro tórica	0.2173.432	0.2173.432	0.2173.432	0.2173.432
18	2	Cojinete	0.3431.748	0.3431.748	0.3431.748	0.3431.748
19	1	Junto de labio	0.2233.010	0.2233.010	0.2233.010	0.2233.010
19	1	Junto de mecánica	0.2247.021	0.2247.021	0.2247.021	0.2247.021
20	1	Retén	0.0371.028	0.0371.028	0.0371.028	0.0371.028
21	1	Retén	0.0370.012	0.0370.012	0.0370.012	0.0370.012
21	2	Retén	0.0370.012	0.0370.012	0.0370.012	0.0370.012

Juego recambios:

4,14,16 & 19	09-45587	09-45588	09-45587	09-45587	Junto de labio
4,14,16 & 19	09-46841	09-46842	09-46841	09-46841	Junto de mecánica

Lista de piezas

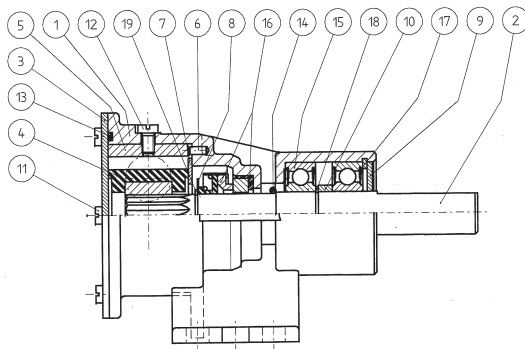

F5B-8

Pos	Nos	Descripción	10-24571-13	10-24571-14	10-24571-15	10-24571-52	Junto de labio
			10-24571-01	10-24571-02	10-24571-03	10-24571-51	Junto de mecánica
1	1	Cuerpo	01-24573-1	01-24573-1	01-24573-1	01-24573-2	
2	1	Eje	01-46744	01-46744	01-46744	01-46746	
3	1	Tapa	01-46747-2	01-46747-2	01-46747-2	01-46747-2	
4	1	Impulsor	09-1027B	09-1027B-9	09-1027B	09-1027B	
5	1	Leva	01-42397	01-42397	01-45014	01-42397	
6	1	Cabilla	01-42400	01-42400	01-42400	01-42400	
7	1	Pletina	01-42399-2	01-42399-2	01-42399-2	01-42399-2	
8	1	Arandela					
8	1	Arandela	01-45680	01-45680	01-45680	01-45680	
9	1	Arandela	01-45047	01-45047	01-45047	01-45047	
10	1	Separador	01-46009	01-46009	01-46009	01-46009	
11	6	Tornillo	0.0279.300	0.0279.300	0.0279.300	0.0279.300	
12	1	Tornillo	01-46794-05	01-46794-05	0.0279.032	01-46794-05	
13	1	Junto aro tórica	0.2173.475	0.2173.475	0.2173.475	0.2173.475	
14	1	Junto aro tórica	0.2173.402	0.2173.402	0.2173.402	0.2173.402	
15	2	Cojinete	0.3431.742	0.3431.742	0.3431.742	0.3431.742	
16	1	Junto de labio	0.2233.012	0.2233.012	0.2233.012	0.2233.012	
16	1	Junto de mecánica	0.2247.022	0.2247.022	0.2247.022	0.2247.022	
17	1	Retén	0.0371.040	0.0371.040	0.0371.040	0.0371.040	
18	1	Retén	0.0370.017	0.0370.017	0.0370.017	0.0370.017	
19	1	Retén					
19	1	Retén	0.0370.516	0.0370.516	0.0370.516	0.0370.516	

Juego recambios:

4, 11, 13 & 16	09-45585	09-45586	09-45585	09-45585	Junto de labio
4, 11, 13 & 16	09-46843	09-46844	09-46843	09-46843	Junto de mecánica

Lista de piezas

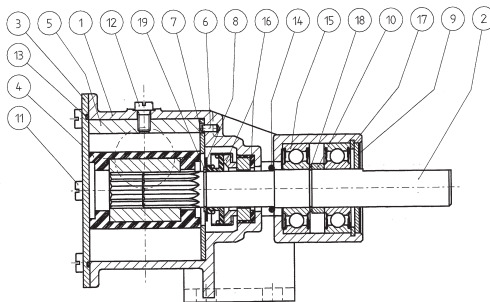

F7B-8

Pos	Nos	Descripción	10-24572-13	10-24572-52	Junto de labio
			10-24572-01	10-24572-51	Junto de mecánica
1	1	Cuerpo	01-24574-3	01-24574-4	
2	1	Eje	01-46744	01-46746	
3	1	Tapa	01-46648-3	01-46648-3	
4	1	Impulsador	09-1028BT-1	09-1028BT-1	
5	1	Leva	01-42679	01-42679	
6	1	Cabilla	01-42400	01-42400	
7	1	Pletina	01-46798-2	01-46798-2	
8	1	Arandela			
8	1	Arandela	01-45680	01-45680	
9	1	Arandela	01-45047	01-45047	
10	1	Separador	01-46009	01-46009	
11	6	Tornillo	0.0279.301	0.0279.301	
12	1	Tornillo	01-46794-01	01-46794-01	
13	1	Junto aro tórica	0.2172.012	0.2172.012	
14	1	Junto aro tórica	0.2173.402	0.2173.402	
15	2	Cojinete	0.3431.742	0.3431.742	
16	1	Junto de labio	0.2233.012	0.2233.012	
16	1	Junto de mecánica	0.2247.022	0.2247.022	
17	1	Retén	0.0371.040	0.0371.040	
18	1	Retén	0.0370.017	0.0370.017	
19	1	Retén			
19	1	Retén	0.0370.516	0.0370.516	

Juego recambios:

4,11,13 & 16	09-47426	09-47426	Junto de labio
4,11,13 & 16	09-47427	09-47427	Junto de mecánica

Lista de piezas

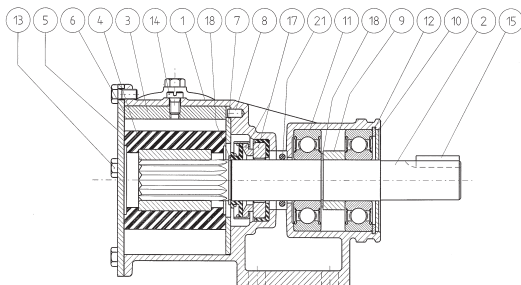

F8B-8 F8B-8007 F8B-8007 F8B-8007

Pos	Nos	Descripción	10-13021-1	10-13021-9	10-13021-95	10-13021-96
1	1	Cuerpo	01-13164-1	01-13164-2	01-13164-3	01-13164-4
2	1	Eje	01-35132	01-35132	01-35746	01-35746
3	1	Leva	01-42680	01-42680	01-42680	01-42680
4	1	Impulsor	09-819B	09-819B	09-819B	09-819B
5	1	Tapa	01-42422-1	01-42422-1	01-42422-1	01-42422-1
6	1	Junta	01-42424	01-42424	01-42424	01-42424
7	1	Pletina	01-42423	01-42423	01-42423	01-42423
8	1	Cabilla	01-42426	01-42426	01-42426	01-42426
9	1	Junto de labio	01-45374	01-45374	01-45374	01-45374
10	1	Arandela	01-45380	01-45380	01-45380	01-45380
11	2	Cojinete	0.3431.780	0.3431.780	0.3431.780	0.3431.780
12	1	Retén	0.0371.062	0.0371.062	0.0371.062	0.0371.062
13	5	Tornillo	0.0138.134	0.0138.134	0.0138.134	0.0138.134
14	1	Tornillo	01-46794-02	01-46794-02	01-46794-02	01-46794-02
15	1	Chaveta	0.0502.231	0.0502.231	-	-
17	1	Junto de mecánica	0.2247.008	0.2247.008	0.2247.008	0.2247.008
18	2	Retén	0.0370.525	0.0370.525	0.0370.525	0.0370.525
21	1	Junto aro tórica	0.2172.573	0.2172.573	0.2172.573	0.2172.573

Juego recambios:

4,6,13,17 & 18	09-45575	09-45575	09-45575	09-45575
----------------	----------	----------	----------	----------

Pompa autodescante di bronzo, montaggio a piedistallo

Applicazioni tipiche

- *Marittimo*
Raffreddamento del motore, pompa di sentina e lavaggio coperta, pompa di lavaggio, svuotamento contenitore di raccolta.
- *Industriale*
Circolazione liquidi e travaso, svuotamento serbatoio e drenaggio scarico del pozzo, trattamento dei solidi in sospensione.

Caratteristiche tecniche

Corpo:	Bronzo
Girante:	Neoprene, EPDM o nitrile
Albero:	Acciaio resistente agli acidi. L'albero è montato su doppi cuscinetti a sfera permanentemente lubrificati.
Guarnizione:	Guarnizione a labbro o meccanico
Camma:	Intera o ridotta
Collegamento:	Vedi "Specificazione del tipo", pagina 39

Dati di pressione e capacità

Vedi pagina 45-47.

Istruzioni per la manutenzione

Vedi elenco delle parti pagina 40-44

Smontaggio

1. Rimuovere il coperchio terminale e la guarnizione.
2. Tirare fuori la girante usando due cacciaviti o altri attrezzi adatti.
3. Rimuovere la camma e pulire le tracce di composto di sigillo sulla camma ed all'interno del corpo della pompa. Togliere la piastra di tenuta.
4. Rimuovere la guarnizione a labbro, e la guarnizione meccanica.

5. Rimuovere la rondella (pos. 9 per F35B-8 – F7B-8 e pos. 10 per F8B-8) inserendo un cacciavite nell'apertura ed alzare la rondella facendo leva.
6. Rimuovere l'anello di fermo dell'assemblaggio del cuscinetto.
7. Rimuovere l'asse con i cuscinetti premendo sulla parte terminale di esso dalla parte della girante.
8. Rimuovere l'anello di fermo dei cuscinetti e lo spaziatore. Su F35B-8, F4B-8 e F8B-8 non premere i cuscinetti sulla superficie della guarnizione.
9. Rimuovere l'o-ring dall'asse

Montaggio

1. Montare l'anello di fermo dei cuscinetti e lo spaziatore sull'asse. Su F35B-8, F4B-8 e F8B-8 non premere i cuscinetti sulla superficie della guarnizione.
2. Montare l'o-ring sull'asse (non su F8B-8).
3. Premere l'asse con i cuscinetti nel corpo della pompa, sistemare l'anello di fermo e la rondella (pos. 9 per F35B-8 – F7B-8 e pos. 10 per F8B-8). Montare l'o-ring pos. 21 (solo su F8B-8)
4. Montare la guarnizione a labbro (molla verso la girante) e la guarnizione meccanica. Montare la piastra di tenuta (pos. 18).
5. Fermare la camma, ma prima di farlo applicare del composto di sigillo sulla camma e sulla vite per prevenire perdite.
6. Lubrificare la girante con lubrificante Johnson ed installarla con un movimento rotatorio nel senso inteso di rotazione.
7. Installate la guarnizione prima di montare il coperchio terminale.

Gestione dei rifiuti/ riciclaggio dei materiali

Al termine della vita del prodotto si prega di smaltire il prodotto secondo le leggi in vigore per queste operazioni. Quando possibile, si raccomanda di smontare il prodotto e riciclare i materiali dei componenti.

Specifica del tipo

F35B-8 Tipo	Art No. Guarnizione a labbro	Art No. Guarnizione meccanico	Girante	Camma	Corpo	Collegamento
F35B-8	10-24569-13	10-24569-01	Neopren	1	01-35881-1	ISO7/1-Rp3/8
F35B-802	10-24569-15	10-24569-03	Neopren	1/2	01-35881-1	ISO7/1-Rp3/8
F35B-8007	10-24569-52	10-24569-51	Neopren	1	01-35881-2	3/8-18NPTF
F35B-8027	10-24569-21	10-24569-09	Neopren	1/2	01-35881-2	3/8-18NPTF

F4B-8 Tipo	Art No. Guarnizione a labbro	Art No. Guarnizione meccanico	Girante	Camma	Corpo	Collegamento
F4B-8	10-24570-13	10-24570-01	Neopren	1	01-35882-1	ISO7/1-Rp3/8
F4B-89	10-24570-14	10-24570-02	Nitril	1	01-35882-1	ISO7/1-Rp3/8
F4B-8007	10-24570-19	10-24570-07	Neopren	1	01-35882-2	3/8-18NPTF
F4B-8007	10-24570-52	10-24570-51	Neopren	1	01-35882-2	3/8-18NPTF

F5B-8 Tipo	Art No. Guarnizione a labbro	Art No. Guarnizione meccanico	Girante	Camma	Corpo	Collegamento
F5B-8	10-24571-13	10-24571-01	Neopren	1	01-24573-1	ISO7/1-Rp3/4
F5B-89	10-24571-14	10-24571-02	Nitril	1	01-24573-1	ISO7/1-Rp3/4
F5B-802	10-24571-15	10-24571-03	Neopren	1/2	01-24573-1	ISO7/1-Rp3/4
F5B-8007	10-24571-52	10-24571-51	Neopren	1	01-24573-2	3/4-14NPTF

F7B-8 Tipo	Art No. Guarnizione a labbro	Art No. Guarnizione meccanico	Girante	Camma	Corpo	Collegamento
F7B-8	10-24572-13	10-24572-01	EPDM	1	01-24574-3	ISO7/1-Rp1
F7B-8007	10-24572-52	10-24572-51	EPDM	1	01-24574-4	1-11 1/2NPTF

F8B-8 Tipo	Art No. Guarnizione a labbro	Art No. Guarnizione meccanico	Girante	Camma	Corpo	Collegamento
F8B-8		10-13021-1	Neopren	1	01-13164-1	ISO7/1-Rp11/2
F8B-8007		10-13021-9	Neopren	1	01-13164-2	11/2-111/2NPTF
F8B-8007		10-13021-95	Neopren	1	01-13164-3	11/4-111/2NPTF
F8B-8007		10-13021-96	Neopren	1	01-13164-4	11/2-111/2NPTF

Elenco delle parti

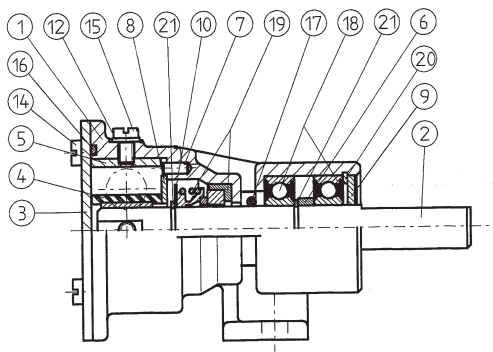

F35B-8

Pos	Nos	Descrizione	10-24569-13	10-24569-15	10-24569-52	10-24569-21	Guarnizioni a labbro
			10-24569-01	10-24569-03	10-24569-51	10-24569-09	Guarnizioni meccanica
1	1	Corpo	01-35881-1	01-35881-1	01-35881-2	01-35881-2	
2	1	Albero	01-46735-1	01-46735-1	01-46740	01-46735-1	
3	1	Coperchio	01-46739-2	01-46739-2	01-46739-2	01-46739-2	
4	1	Girante	09-808B	09-808B	09-808B	09-808B	
5	1	Camma	01-42910	01-42415	01-42910	01-42415	
6	1	Spessore	01-45542	01-45542	01-45542	01-45542	
7	1	Spina	01-42400	01-42400	01-42400	01-42400	
8	1	Piastra	01-46676	01-46676	01-46676	01-46676	
9	1	Rondella	01-45049	01-45049	01-45049	01-45049	
10	1	Rondella					
10	1	Rondella	01-45659	01-45659	01-45659	01-45659	
12	1	Rondella	01-46790-01	01-46790-01	01-46790-01	01-46790-01	
14	4	Vite	0.0279.300	0.0279.300	0.0279.300	0.0279.300	
15	1	Vite	01-46974-03	01-46794-10	01-46794-03	01-46794-10	
16	1	Guarnizioni coperchio	0.2173.440	0.2173.440	0.2173.440	0.2173.440	
17	1	Guarnizioni coperchio	0.2173.432	0.2173.432	0.2173.432	0.2173.432	
18	2	Cuscinetto	0.3431.748	0.3431.748	0.3431.748	0.3431.748	
19	1	Guarnizioni a labbro	0.2233.010	0.2233.010	0.2233.010	0.2233.010	
19	1	Guarnizioni meccanica	0.2247.021	0.2247.021	0.2247.021	0.2247.021	
20	1	Anello di fermo	0.0371.028	0.0371.028	0.0371.028	0.0371.028	
21	1	Anello di fermo	0.0370.012	0.0370.012	0.0370.012	0.0370.012	
21	2	Anello di fermo	0.0370.012	0.0370.012	0.0370.012	0.0370.012	

Kit di servizio:

4,14,16&19	09-45589	09-45589	09-45589	09-45589	Guarnizioni a labbro
4,14,16&19	09-46840	09-46840	09-46840	09-46840	Guarnizioni meccanica

Elenco delle parti

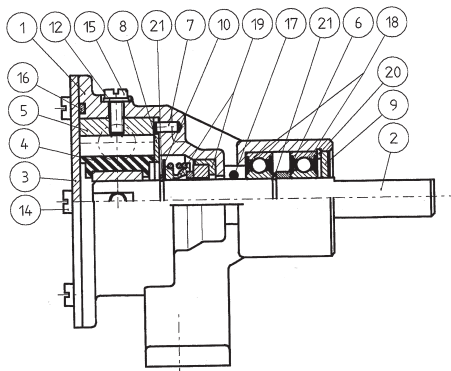

F4B-8

Pos	Nos	Descrizione	10-24570-13	10-24570-14	10-24570-19	10-24570-52	Guarnizioni a labbro
			10-24570-01	10-24570-02	10-24570-07	10-24570-51	Guarnizioni meccanica
1	1	Corpo	01-35882-1	01-35882-1	01-35882-2	01-35882-2	
2	1	Albero	01-46735-1	01-46735-1	01-46735-1	01-46740	
3	1	Coperchio	01-46007-2	01-46007-2	01-46007-2	01-46007-2	
4	1	Girante	09-810B	09-810B-9	09-810B	09-810B	
5	1	Camma	01-42389	01-42389	01-42389	01-42389	
6	1	Spessore	01-45542	01-45542	01-45542	01-45542	
7	1	Spina	01-42400	01-42400	01-42400	01-42400	
8	1	Piastra	01-46737-2	01-46737-2	01-46737-2	01-46737-2	
9	1	Rondella	01-45049	01-45049	01-45049	01-45049	
10	1	Rondella					
10	1	Rondella	01-45659	01-45659	01-45659	01-45659	
12	1	Rondella	01-46790-01	01-46790-01	01-46790-01	01-46790-01	
14	6	Vite	0.0279.300	0.0279.300	0.0279.300	0.0279.300	
15	1	Vite	01-46794-04	01-46794-04	01-46794-04	01-46794-04	
16	1	Guarnizioni coperchio	0.2173.476	0.2173.476	0.2173.476	0.2173.476	
17	1	Guarnizioni coperchio	0.2173.432	0.2173.432	0.2173.432	0.2173.432	
18	2	Cuscinetto	0.3431.748	0.3431.748	0.3431.748	0.3431.748	
19	1	Guarnizione a labbro	0.2233.010	0.2233.010	0.2233.010	0.2233.010	
19	1	Guarnizione meccanica	0.2247.021	0.2247.021	0.2247.021	0.2247.021	
20	1	Anello di fermo	0.0371.028	0.0371.028	0.0371.028	0.0371.028	
21	1	Anello di fermo	0.0370.012	0.0370.012	0.0370.012	0.0370.012	
21	2	Anello di fermo	0.0370.012	0.0370.012	0.0370.012	0.0370.012	

Kit di servizio:

4,14,16 & 19	09-45587	09-45588	09-45587	09-45587	Guarnizioni a labbro
4,14,16 & 19	09-46841	09-46842	09-46841	09-46841	Guarnizione meccanica

Elenco delle parti

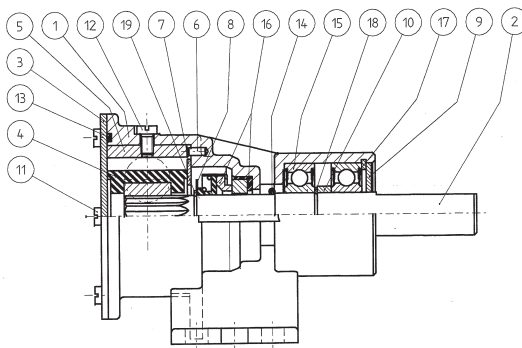

F5B-8

Pos	Nos	Descrizione	10-24571-13	10-24571-14	10-24571-15	10-24571-52	Guarnizioni a labbro
			10-24571-01	10-24571-02	10-24571-03	10-24571-51	Guarnizioni meccanica
1	1	Corpo	01-24573-1	01-24573-1	01-24573-1	01-24573-2	
2	1	Albero	01-46744	01-46744	01-46744	01-46746	
3	1	Coperchio	01-46747-2	01-46747-2	01-46747-2	01-46747-2	
4	1	Girante	09-1027B	09-1027B-9	09-1027B	09-1027B	
5	1	Camma	01-42397	01-42397	01-45014	01-42397	
6	1	Spina	01-42400	01-42400	01-42400	01-42400	
7	1	Piastra	01-42399-2	01-42399-2	01-42399-2	01-42399-2	
8	1	Rondella					
8	1	Rondella	01-45680	01-45680	01-45680	01-45680	
9	1	Rondella	01-45047	01-45047	01-45047	01-45047	
10	1	Spessore	01-46009	01-46009	01-46009	01-46009	
11	6	Vite	0.0279.300	0.0279.300	0.0279.300	0.0279.300	
12	1	Vite	01-46794-05	01-46794-05	0.0279.032	01-46794-05	
13	1	Guarnizioni coperchio	0.2173.475	0.2173.475	0.2173.475	0.2173.475	
14	1	Guarnizioni coperchio	0.2173.402	0.2173.402	0.2173.402	0.2173.402	
15	2	Cuscinetto	0.3431.742	0.3431.742	0.3431.742	0.3431.742	
16	1	Guarnizioni a labbro	0.2233.012	0.2233.012	0.2233.012	0.2233.012	
16	1	Guarnizioni meccanica	0.2247.022	0.2247.022	0.2247.022	0.2247.022	
17	1	Anello di fermo	0.0371.040	0.0371.040	0.0371.040	0.0371.040	
18	1	Anello di fermo	0.0370.017	0.0370.017	0.0370.017	0.0370.017	
19	1	Anello di fermo					
19	1	Anello di fermo	0.0370.516	0.0370.516	0.0370.516	0.0370.516	

Kit di servizio:

4,11,13 & 16	09-45585	09-45586	09-45585	09-45585	Guarnizioni a labbro
4,11,13 & 16	09-46843	09-46844	09-46843	09-46843	Guarnizioni meccanica

Elenco delle parti

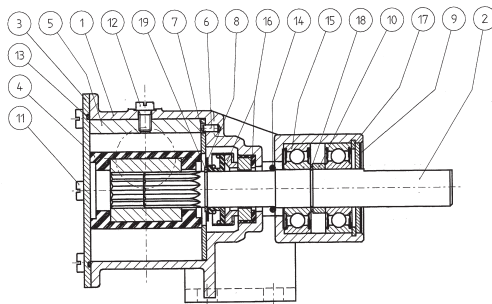

F7B-8

Pos	Nos	Descrizione	10-24572-13	10-24572-52	Guarnizioni a labbro
			10-24572-01	10-24572-51	Guarnizioni meccanica
1	1	Corpo	01-24574-3	01-24574-4	
2	1	Albero	01-46744	01-46746	
3	1	Coperchio	01-46648-3	01-46648-3	
4	1	Girante	09-1028BT-1	09-1028BT-1	
5	1	Camma	01-42679	01-42679	
6	1	Spina	01-42400	01-42400	
7	1	Piastra	01-46798-2	01-46798-2	
8	1	Rondella			
8	1	Rondella	01-45680	01-45680	
9	1	Rondella	01-45047	01-45047	
10	1	Spessore	01-46009	01-46009	
11	6	Vite	0.0279.301	0.0279.301	
12	1	Vite	01-46794-01	01-46794-01	
13	1	Guarnizioni coperchio	0.2172.012	0.2172.012	
14	1	Guarnizioni coperchio	0.2173.402	0.2173.402	
15	2	Cuscinetto	0.3431.742	0.3431.742	
16	1	Guarnizioni a labbro	0.2233.012	0.2233.012	
16	1	Guarnizioni meccanica	0.2247.022	0.2247.022	
17	1	Anello di fermo	0.0371.040	0.0371.040	
18	1	Anello di fermo	0.0370.017	0.0370.017	
19	1	Anello di fermo			
19	1	Anello di fermo	0.0370.516	0.0370.516	

Kit di servizio:

4,11,13 & 16	09-47426	09-47426	Guarnizioni a labbro
4,11,13 & 16	09-47427	09-47427	Guarnizioni meccanica

Elenco delle parti

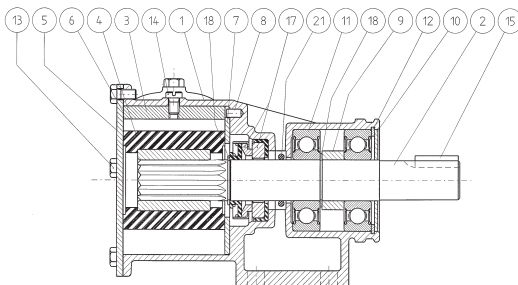

F8B-8 F8B-8007 F8B-8007 F8B-8007

Pos	Nos	Descrizione	10-13021-1	10-13021-9	10-13021-95	10-13021-96
1	1	Corpo	01-13164-1	01-13164-2	01-13164-3	01-13164-4
2	1	Albero	01-35132	01-35132	01-35746	01-35746
3	1	Camma	01-42680	01-42680	01-42680	01-42680
4	1	Girante	09-819B	09-819B	09-819B	09-819B
5	1	Coperchio	01-42422-1	01-42422-1	01-42422-1	01-42422-1
6	1	Guarnizioni coperchio	01-42424	01-42424	01-42424	01-42424
7	1	Piastra	01-42423	01-42423	01-42423	01-42423
8	1	Spina	01-42426	01-42426	01-42426	01-42426
9	1	Spessore	01-45374	01-45374	01-45374	01-45374
10	1	Rondella	01-45380	01-45380	01-45380	01-45380
11	2	Cuscinetto	0.3431.780	0.3431.780	0.3431.780	0.3431.780
12	1	Anello di fermo	0.0371.062	0.0371.062	0.0371.062	0.0371.062
13	5	Vite	0.0138.134	0.0138.134	0.0138.134	0.0138.134
14	1	Vite	01-46794-02	01-46794-02	01-46794-02	01-46794-02
15	1	Chiavella	0.0502.231	0.0502.231	-	-
17	1	Guarnizioni meccanica	0.2247.008	0.2247.008	0.2247.008	0.2247.008
18	2	Anello di fermo	0.0370.525	0.0370.525	0.0370.525	0.0370.525
21	1	Guarnizioni coperchio	0.2172.573	0.2172.573	0.2172.573	0.2172.573

Kit di servizio:

4,6,13,17 & 18	09-45575	09-45575	09-45575	09-45575
----------------	----------	----------	----------	----------

Tryck- och kapacitetsdata

(baserad på vatten vid 20°C/68°F, helkam och neoprenimpeller)

Pressions et débits

(eau à 20°C/68°F, came hauteur maxi et rotor néoprène)

Pressure and capacity data

(based on water at 20°C/68°F, full cam and impeller neoprene)

Caudales y presiones

(con agua a 20°C/68°F, leva entera y impulsor de neopreno)

Druck und Leistungsdaten

(basierend auf Wasser bei 20°C/68°F, 1/1 Kamm und Impeller Neopren)

Dati di pressione e capacità

(per acqua a 20°C/68°F, gamma intera e girante in neoprene)

F5B-8

Bar	700 rpm			900 rpm			1,400 rpm			1,750 rpm			2,000 rpm				
	kPa	ft	USGPM	kW	I/min	USGPM	kW	I/min	USGPM	kW	I/min	USGPM	kW	I/min	USGPM		
0.3	30	10.1	0.13	16.0	4.2	0.18	21.0	5.5	0.37	33.0	8.7	0.37	41.0	10.8	0.37	46.0	12.2
0.6	60	20.1	0.13	15.0	4.0	0.18	20.0	5.3	0.37	32.0	8.5	0.37	39.5	10.4	0.37	45.0	11.9
1.0	100	33.5	0.13	14.0	3.7	0.18	19.0	5.0	0.37	30.0	7.9	0.37	37.0	9.8	0.37	42.0	11.1
1.5	150	50.3	0.13	13.0	3.4	0.18	17.0	4.5	0.37	27.0	7.1	0.37	33.5	8.9	0.37	38.0	10.0
2.0	200	67.1	—	—	—	—	—	—	0.37	22.0	5.8	0.37	28.5	7.5	0.37	33.0	8.7

Reducerad kam - 40-50% lägre kapacitet.

Nitrilimpeller - ca 30% lägre tryck.

Reduced cam - 40-50% lower capacity.

Impeller of nitrile - adjust total head approx. 30% down.

Mit reduziertem Kamm verringert sich die Leistung um ca. 40-50%.

Bei Nitril Impellers verringert sich die Leistung um ca. 30%.

Came réduite - débit inférieur d'environ 40-50%.

Rotor en nitrile - hauteur de refoulement environ 30% inférieure.

Leva reducida - Reduce caudal 40-50%.

Impulsor de nitrilo - reduce la presión aproximadamente el 30%.

Gamma ridotta - capacità inferiore del 40-50%.

Girante in nitrile - la prevalenza totale è inferiore del 30% circa.

F7B-8

Bar	700 rpm			900 rpm			1,400 rpm			1,750 rpm			2,000 rpm				
	kPa	ft	USGPM	kW	I/min	USGPM	kW	I/min	USGPM	kW	I/min	USGPM	kW	I/min	USGPM		
0.3	30	10.1	0.37	36.0	9.5	0.37	46.0	12.2	0.75	74.0	19.6	0.75	98.0	25.9	0.75	107.0	28.3
0.6	60	20.1	0.37	34.0	9.0	0.37	44.0	11.6	0.75	72.0	19.0	0.75	96.0	25.4	0.75	104.0	27.5
1.0	100	33.5	0.37	29.0	7.7	0.37	40.0	10.6	0.75	67.0	17.7	0.75	87.0	23.0	0.75	98.0	25.9
1.8	180	60.4	0.37	21.0	5.5	0.37	30.0	7.9	0.75	57.0	15.1	0.75	73.0	19.3	0.75	84.0	22.2
2.5	250	83.8	—	—	—	—	—	—	0.75	37.0	9.8	1.1	52.0	13.7	1.1	63.0	16.6

Reducerad kam - 30-45% lägre kapacitet.

Nitrilimpeller - ca 30% lägre tryck.

Reduced cam - 30-45% lower capacity.

Impeller of nitrile - adjust total head approx. 30% down.

Mit reduziertem Kamm verringert sich die Leistung um ca. 30-45%.

Bei Nitril Impellers verringert sich die Leistung um ca. 30%.

Came réduite - débit inférieur d'environ 30-45%.

Rotor en nitrile - hauteur de refoulement environ 30% inférieure.

Leva reducida - Reduce caudal 30-45%.

Impulsor de nitrilo - reduce la presión aproximadamente el 30%.

Gamma ridotta - capacità inferiore del 30-45%.

Girante in nitrile - la prevalenza totale è inferiore del 30% circa.

Tryck- och kapacitetsdata

(baserad på vatten vid 20°C/68°F, helkam och neoprenimpeller)

Pressions et débits

(eau à 20°C/68°F, came hauteur maxi et rotor néoprène)

Pressure and capacity data

(based on water at 20°C/68°F, full cam and impeller neoprene)

Caudales y presiones

(con agua a 20°C/68°F, leva entera y impulsor de neopreno)

Druck und Leistungsdaten

(basierend auf Wasser bei 20°C/68°F, 1/1 Kamm und Impeller Neopren)

Dati di pressione e capacità

(per acqua a 20°C/68°F, gamma intera e girante in neoprene)

F8B-8

Bar	kPa	700 rpm			900 rpm			1,400 rpm			1,750 rpm			2,000 rpm			
		ft	kW	I/min	USGPM	kW	I/min	USGPM	kW	I/min	USGPM	kW	I/min	USGPM	kW	I/min	USGPM
0.3	30	10.1	0.37	87.0	23.0	0.75	114.0	30.1	1.1	188.0	50.0	1.5	241.0	63.7	1.5	279.0	73.7
0.6	60	20.1	0.55	80.0	21.1	0.75	107.0	28.3	1.1	180.0	47.6	1.5	233.0	61.6	1.5	270.0	71.3
1.0	100	33.5	0.55	73.0	19.3	0.75	101.0	26.7	1.1	177.0	46.8	1.5	228.0	60.2	1.5	264.0	69.7
1.8	180	60.4	—	—	—	1.1	70.0	18.5	1.1	148.0	39.1	2.2	203.0	53.6	2.2	242.0	63.4
2.5	250	83.8	—	—	—	—	—	—	1.1	108.0	28.5	2.2	166.0	43.9	2.2	208.0	55.0

Reducerad kam - 35-40% lägre kapacitet.

Nitrilimpeller - ca 30% lägre tryck.

Reduced cam - 35-40% lower capacity.

Impeller of nitrile - adjust total head approx. 30% down.

Mit reduzierterem Kamm verringert sich die Leistung um 35-40%.

Bei Nitril Impellers verringert sich die Leistung um ca. 30%.

Came réduite - débit inférieur d'environ 35-40%.

Rotor en nitrile - hauteur de refoulement environ 30% inférieure.

Leva reducida - Reduce caudal 35-40%.

Impulsor de nitrilo - reduce la presión aproximadamente el 30%.

Gamma ridotta - capacità inferiore del 35-40%.

Girante in nitrile - la prevalenza totale è inferiore del 30% circa.

Pump	Art. No.	A	B	C	D	E	F	G	H	K
F35B-8	10-24569-01/13	30	53,7	93,7	109	11	30	BSP3/8"	ø7 (2x)	52
F35B-802	10-24569-03/15	30	53,7	93,7	109	11	30	BSP3/8"	ø7 (2x)	52
F35B-8007	10-24569-51/52	30	53,7	93,7	109	11	30	NPTF3/8"	ø7 (2x)	52
F35B-8027	10-24569-09/21	30	53,7	93,7	109	11	30	NPTF3/8"	ø7 (2x)	52
F4B-8	10-24570-01/13	30	76,7	94,2	111	17,5	50	BSP3/8"	ø9 (2x)	52-57,2
F4B-89	10-24570-02/14	30	76,7	94,2	111	17,5	50	BSP3/8"	ø9 (2x)	52-57,2
F4B-8007	10-24570-07/19	30	76,7	94,2	111	17,5	50	NPTF3/8"	ø9 (2x)	52-57,2
F4B-8007	10-24570-51/52	30	76,7	94,2	111	17,5	50	NPTF3/8"	ø9 (2x)	52-57,2
F5B-8	10-24571-01/13	40	81	130	151	14,3	50	BSP3/4"	ø9 (4x)	70
F5B-89	10-24571-02/14	40	81	130	151	14,3	50	BSP3/4"	ø9 (4x)	70
F5B-802	10-24571-03/15	40	81	130	151	14,3	50	BSP3/4"	ø9 (4x)	70
F5B-8007	10-24571-51/52	40	81	130	151	14,3	50	NPTF3/4"	ø9 (4x)	70
F7B-8	10-24572-01/13	40	81	138,2	170	14,3	50	BSP1"	ø9 (4x)	70
F7B-8007	10-24572-51/52	40	81	138,2	170	14,3	50	NPTF1"	ø9 (4x)	70
F8B-8	10-13021-1	50	81,5	177,5	217	27	65	BSP1.1/2"	ø10,5 (4x)	80
F8B-8007	10-13021-9	50	81,5	177,5	217	27	65	NPTF1.1/2"	ø10,5 (4x)	80
F8B-8007	10-13021-95	50	139	177,5	217	27	65	NPTF1.1/4"	ø10,5 (4x)	114
F8B-8007	10-13021-96	50	139	177,5	217	27	65	NPTF1.1/2"	ø10,5 (4x)	114

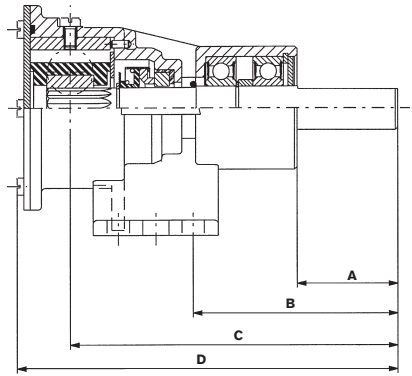
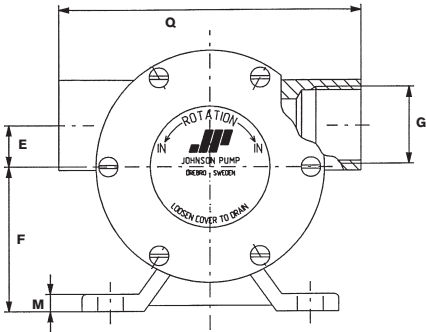

L	M	N	P	Q	R	S	T	U	Weight
66	5	-	23	80	12k6	11	-	-	0.5 kg
66	5	-	23	80	12k6	11	-	-	0.5 kg
66	5	-	23	80	9,525 +0/-0,013	8,7	-	-	0.5 kg
66	5	-	23	80	12k6	11	-	-	0.5 kg
75	6	-	25	80	12k6	11	-	-	0.8 kg
75	6	-	25	80	12k6	11	-	-	0.8 kg
75	6	-	25	80	12k6	11	-	-	0.8 kg
75	6	-	25	80	9,525 +0/-0,013	8,7	-	-	0.8 kg
90	6	30	50	106	17k6	16	-	-	1.6 kg
90	6	30	50	106	17k6	16	-	-	1.6 kg
90	6	30	50	106	17k6	16	-	-	1.6 kg
90	6	30	50	106	15,875 +0/-0,013	13,375	5P9	-	1.6 kg
90	6	30	50	120	17k6	16	-	-	1.9 kg
90	6	30	50	120	15,875 +0/-0,013	13,375	5P9	-	1.9 kg
105	10	45	70	160	24h8	20	8	27	5.9 kg
105	10	45	70	160	24h8	20	8	27	5.9 kg
140	8	38	59	160	25,4 +0/-0,025	21,6	6,35	-	5.9 kg
140	8	38	59	160	25,4 +0/-0,025	21,6	6,35	-	5.9 kg

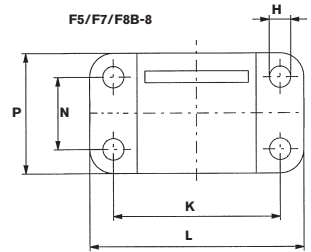
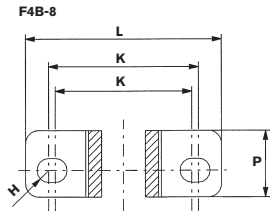
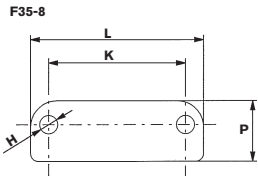

F35/F4/F5/F7B-8

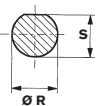

F5/F7/F8B-8

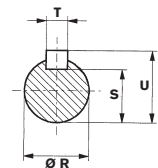

Tillbehör

Vakuumbrytare 09-45053

- För automatisk avstängning.
- För att förhindra skada på pumpen.

Vakuumbrytaren passar alla självsugande impellerpumpar och ska användas vid t ex länsning/tömning av tank för att förhindra torrkörning.

Vakuumbrytaren stänger automatiskt av pumpen när kölsvinet/tanken är tömd. Med en vakuumbrytare installerad kan pumpen startas antingen genom fjärrstyrning eller manuellt genom att trycka på knappen på vakuumbrytaren.

Zubehör

Vakuumschalter 09-45053

- Zum automatischen Abschalten der Pumpe.
- Zum Schutz der Pumpe vor Beschädigung.

Der Vakuumschalter kann bei allen selbstansaugenden Impellerpumpen eingesetzt werden. Z.B. bei Bilge- oder Tankentleerungspumpen dient der Schalter zum Schutz der Pumpe vor Trockenlauf. Der Vakuumschalter schaltet die Pumpe ab, wenn die Bilge oder der Tank leer ist. Mit dem am Vakuumschalter befindlichen Schalter kann die Pumpe entweder durch Drücken des Druck-schalters oder des Hebels wieder gestartet werden.

Accesorios

Interruptor automático 09-45053

- Para desconexión automática.
- Para evitar averías de la bomba.

El interruptor de vacío puede conectarse a todas las bombas autocebantes y debe utilizarse en las bombas de achique o de trasiego para evitar que trabajen en seco.

El interruptor de vacío desconecta automáticamente la bomba, cuando el depósito está vacío. Cuando se instala este interruptor, podrá conectarse la bomba con un pulsador a distancia o presionado la palanca del interruptor de vacío.

Accessories

Vacuum switch 09-45053

- For automatic shut off operation.
- To prevent pump damage.

The vacuum switch works with all self-priming impeller pumps and should be used for e.g. bilge pumping/emptying of tanks to prevent the pump from running dry.

The vacuum switch automatically shuts the pump off when the bilge/tank is dry. With the switch fit-ted, you can start the pump by remote push button or manually by depressing lever on the switch.

Accessoires

Contacteur à dépression 09-45053

- Pour arrêt automatique de la pompe.
- Pour éviter d'endommager la pompe.

Le contacteur à dépression fonctionne sur toutes les pompes auto-amorçantes à rotor et devrait être utilisé pour le pompage de cales ou la vidange de réservoirs afin d'éviter à la pompe de fonctionner à sec. Le contacteur à dépression arrête automatiquement la pompe quand la cale ou le réservoir est vide. Avec le contacteur à dépression, il est possible de commander la pompe à distance ou en appuyant sur le levier du contacteur.

Accessori

Interruttore di vuoto 09-45053

- Per il disinserimento automatico della pompa.
- Per impedire che la pompa venga danneggiata.

L'interruttore di vuoto funziona con tutte le pompe a girante autodescanti e deve essere utilizzato, ad esempio, per lo svuotamento della sentina o di serbatoi, per evitare che la pompa funzioni a secco.

L'interruttore di vuoto disinserisce automaticamente la pompa quando la sentina o il serbatoio sono asciutti. Con l'interruttore installato è possibile avviare la pompa a distanza, mediante il pulsante apposito, oppure manualmente, azionando la leva che si trova sull'interruttore.

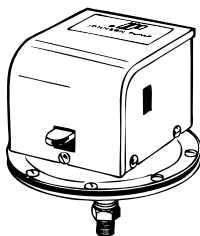



SPX Johnson Pump Marine AB
Nastagatan 19, P.O. Box 1436
SE-701 14 Örebro, Sweden
Phone: +46 (0)19 21 83 00 Fax: +46 (0)19 27 23 72
E-mail: johnson-pump.marine@processequipment.spx.com



For more information about our worldwide locations, approvals, certifications, and local representatives, please visit www.johnson-pump.com.

SPX Corporation reserves the right to incorporate our latest design and material changes without notice or obligation. Design features, materials of construction and dimensional data, as described in this bulletin, are provided for your information only and should not be relied upon unless confirmed in writing.

Copyright © 2009 SPX Corporation