

Impeller Identification Guide

Impeller Identification Guide

Take good care of the cooling system
-change to a new impeller every year

The impeller is a very important security device. Its task is to pump the water through the cooling system of the engine. But remember that the impeller should be replaced every year. And always make sure you get a Johnson Pump original impeller. Then you'll know that it matches your pump exactly.

This is how to remove the old impeller

Remove the impeller with a slip joint plier or a Johnson Pump Impuller.

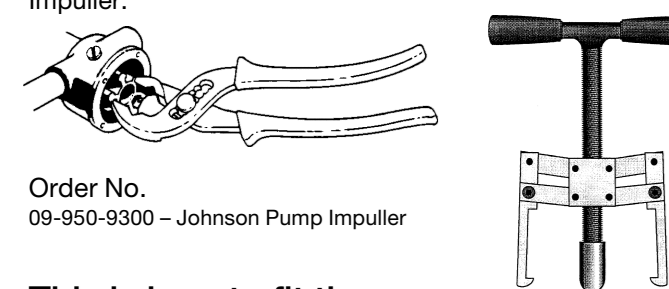

Order No.
09-950-9300 – Johnson Pump Impuller

This is how to fit the new one

Lubricate the shaft and the inside of the pump body and endcover. Use soap, grease or oil. By doing so you avoid dry friction when you start the engine. Mount the impeller by making a pushing and twisting movement in the rotating direction.

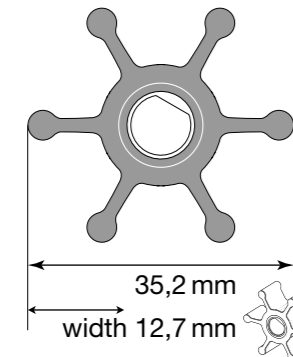
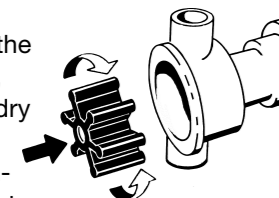

F2

Impeller article number
09-1077B-9
Nitrile (oil resistant)

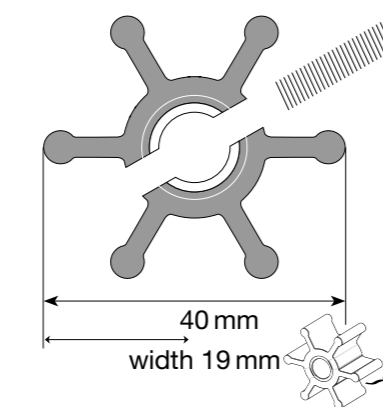

F35

Impeller article number
09-806B
Neoprene (for cooling)
replaces Jabsco 4528-0001
Europe & USA

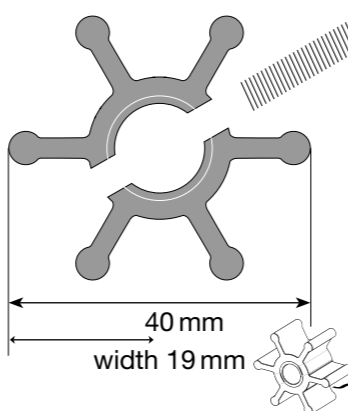

F3

Impeller article number
09-1052S-9
Nitrile (oil resistant)

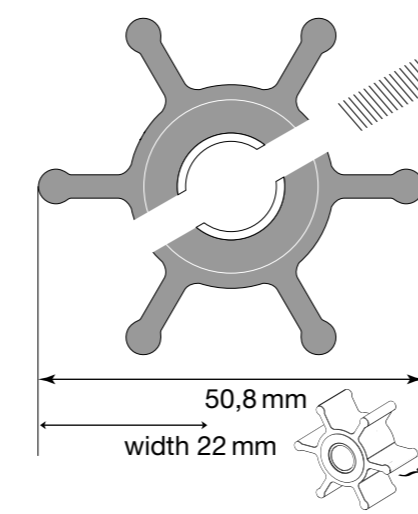

F4

Impeller article number
09-810B
Neoprene (for cooling)
replaces Jabsco 18653-0001
Europe & USA
Impeller article number
09-810B-9
Nitrile (oil resistant)
inner diameter 12 mm

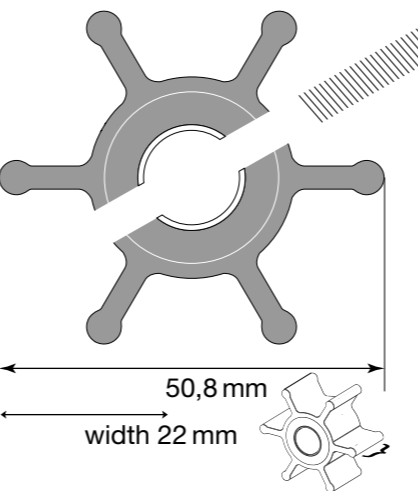

Impeller article number
09-1026B
Neoprene (for cooling)
replaces Jabsco 673-0001
Europe & USA
Impeller article number
09-1026B-9
Nitrile (oil resistant)
replaces Jabsco 673-0003
Europe & USA
inner diameter 12,7 mm

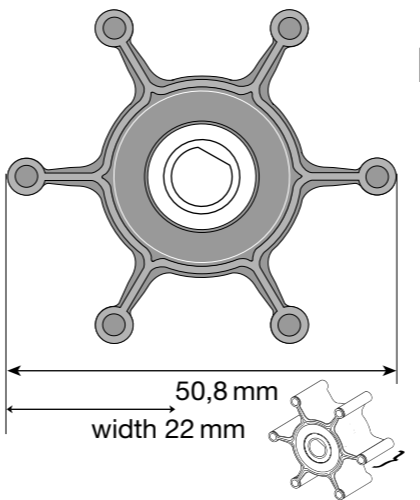

F4

Impeller article number
09-824P-9
Nitrile (oil resistant)
replaces Jabsco 6303-0003
Europe & USA

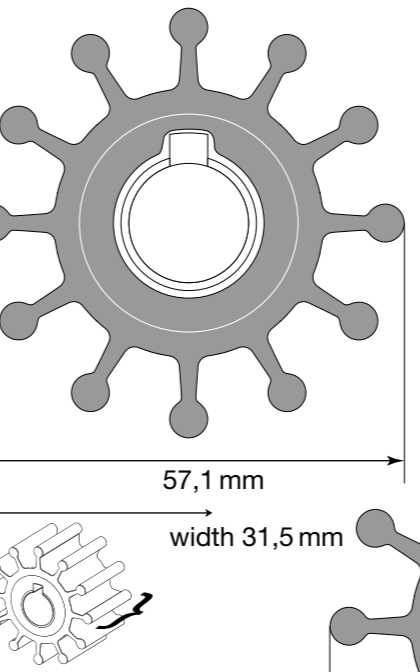

F5

Impeller article number
09-801B
Neoprene (for cooling)
replaces Jabsco 4568-0001

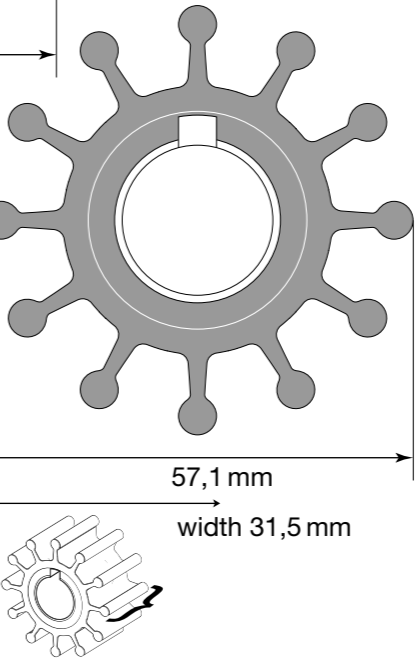

F5

Impeller article number
09-804B-9
Nitrile (oil resistant)
inner diameter 20 mm/key

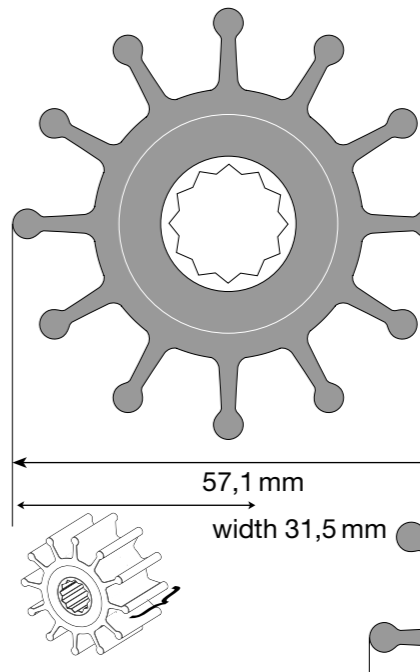

F5

Impeller article number
09-1027B
Neoprene (for cooling)
replaces Jabsco 1210-0001
Europe & USA
Impeller article number
09-1027B-9
Nitrile (oil resistant)
replaces Jabsco 1210-0003
Europe & USA

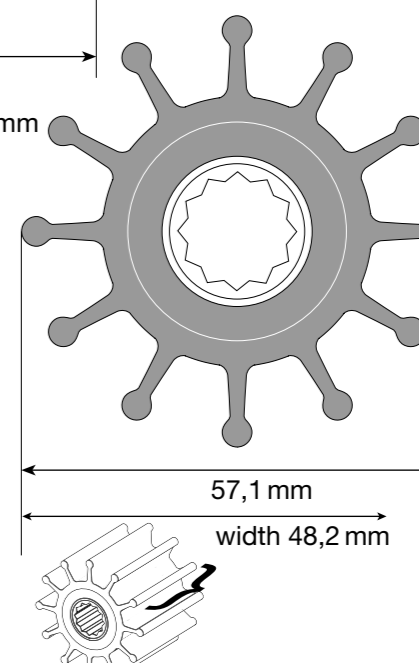

F5

Impeller article number
09-812B
Neoprene (for cooling)
replaces Jabsco 13554-0001 USA

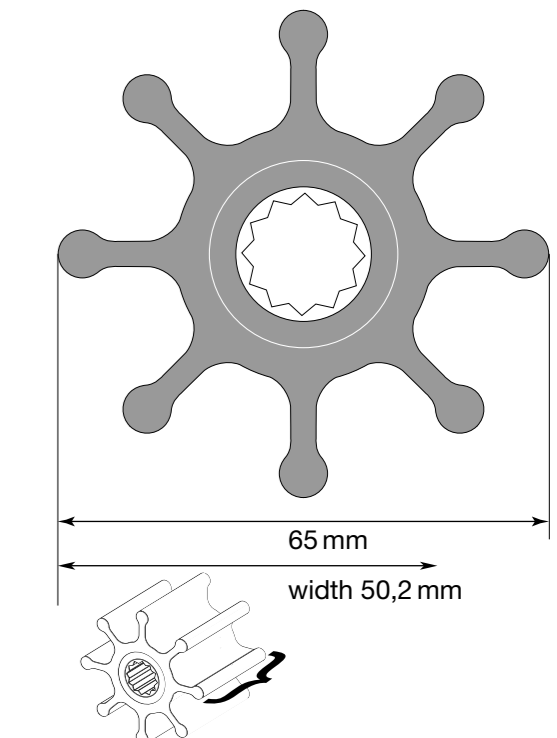

F7

Impeller article number
09-1028B
Neoprene (for cooling)
replaces Jabsco 17937-0001
Europe & USA
Impeller article number
09-1028B-9
Nitrile (oil resistant)
replaces Jabsco 17937-0003
Europe & USA