

MAX POWER

VERTICAL RETRACTABLE THRUSTER

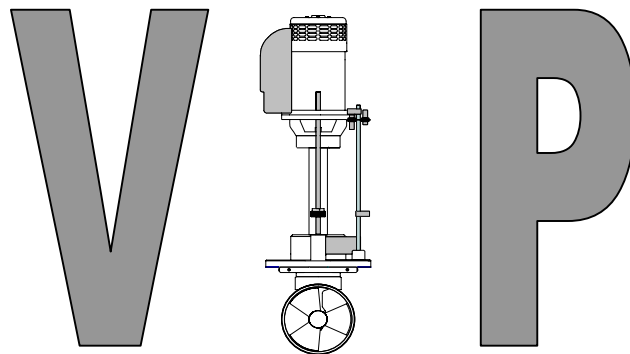

VIP 150 Electric 12 / 24 V

INSTALLATION OPERATION MAINTENANCE

Serial Number : _____

Date of Installation : _____

THIS MANUAL MUST BE KEPT ON BOARD AT ALL TIMES

10 allée François Coli – F 06210 CANNES-MANDELIEU FRANCE.
Tél. +33 (0)492 19 60 60 Fax + 33 (0)492 19 60 61
www.max-power.com e-mail : mp@max-power.com

BEFORE STARTING THE INSTALLATION, IT IS RECOMMENDED TO CAREFULLY READ THE FOLLOWING GUIDE.

TABLE OF CONTENTS

Number	Description	Page
1.	POSITIONING	3
2.	DETERMINE THE LOCATION OF THE AUXILIARY EQUIPMENT	3
3.	MECHANICAL INSTALLATION	
3.1.	<i>MOUNTINING BASE INSTALLATION</i>	4 - 5
3.2.	<i>CONSTRUCTION OF HULL OPENING & CLOSING PLATE</i>	6
3.3.	<i>FINAL FITTING OF THE THRUSTER UNIT TO THE MOUNTING BASE</i>	6
3.4.	<i>FINAL ADJUSTMENT OF THE CLOSING PLATE</i>	7 - 8
4.	ELECTRICAL INSTALLATION	
4.1.	<i>GENERAL</i>	8
4.2.	<i>POWER CABLE SELECTION</i>	9
4.3.	<i>POWER FUSE</i>	9
4.4.	<i>BATTERY REQUIREMENTS</i>	10
4.5.	<i>BATTERY ISOLATOR</i>	10
4.6.	<i>CONTROL CIRCUIT</i>	11
4.7.	<i>CONTROL PANEL AND THRUSTER CONTROL BOX FUNCTIONS</i>	12- 13
5.	TESTS & CHECKS	
5.1.	<i>BEFORE LAUNCHING</i>	14
5.2.	<i>AFTER LAUNCHING</i>	14
6.	OPERATION LIMITATIONS	14
7.	BASIC MAINTENANCE	
7.1.	<i>CONTROL PANEL</i>	15
7.2.	<i>THRUSTER MOTOR & RELAY</i>	15
7.3.	<i>BATTERIES</i>	15
7.4.	<i>COMPOSITE DRIVE LEG</i>	15
7.5.	<i>BRONZE DRIVE LEG</i>	16
7.6.	<i>GENERAL</i>	16
8.	DRAWINGS & DIAGRAMS	
8.1.	<i>PRINCIPAL DIMENSIONS</i>	17
8.2.	<i>BUILD DRAWINGS</i>	18
8.3.	<i>WIRING DIAGRAM</i>	19
8.4.	<i>ELECTRONIC CONTROL BOX CONNECTIONS</i>	20
8.5.	<i>WIRING OF ADDITIONAL CONTROL PANELS FOR VIP THRUSTERS</i>	21
9.	PARTS LISTS & DIAGRAMS	
9.1.	<i>PARTS LIST & DIAGRAM: A</i>	23
9.2.	<i>PARTS DIAGRAM: B</i>	24
9.3.	<i>PARTS LIST: B</i>	25
10.	WARRANTY COVERAGE	26 - 27
11.	DISTRIBUTER CONTACT LIST	28 - 29
12.	WARRANTY FORM	30

Your thruster is a high quality technical product and should be treated as such. The employment of a **qualified marine technician**, with experience in bow thruster installation, is strongly advised. Where possible, the boat manufacturer's architects, design departments and/or shipyards should be consulted, prior to the installation of the unit. For any boat requiring official classification, bodies of approval should also be consulted at the earliest opportunity. In any case, all other bodies, governmental or otherwise, should be contacted to ensure conformity with legal regulations relating to the boat in question.

Your thruster should be delivered with the following parts:

Thruster assembly complete with thruster motor, directional control relay, relay cover, motor support, motor coupling, up / down motors, driveleg and propellers.	Control Box	Joystick control panel (black)
Control Cable 25m	Manual	

1. POSITIONING

- Consider the following, when determining the position of the thruster unit in order to ensure the most efficient operation:

- Find the point the farthest forward (or aft), while keeping in mind the space available, given the vessel's fixtures, space and shape and while respecting the minimum immersion depth of one full turbine diameter (185 mm).

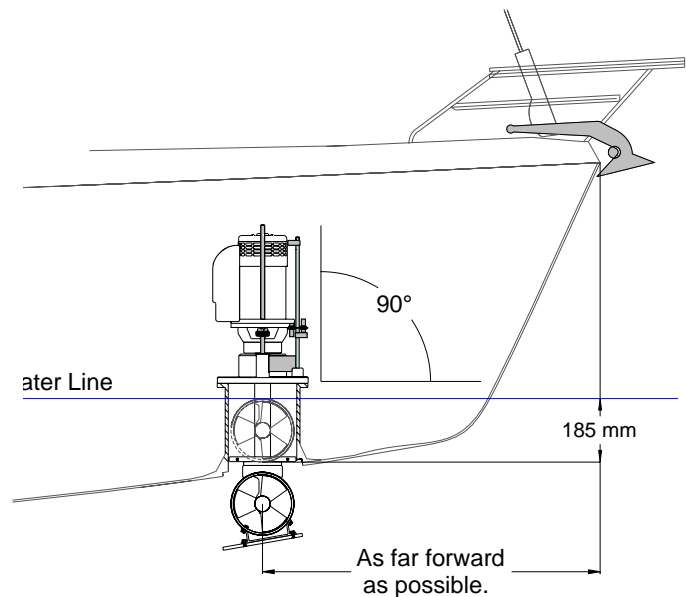

- Always check and make sure that there is enough room to allow for the complete removal of the VIP unit and enough room for the connection of the electric power cables. These cables must be able to flex freely without kinking when the VIP goes up and down.
- To install a VIP in the stern, make sure that the turbine flow is clear of all obstacles, or select the best possible compromise.

2. DETERMINE THE LOCATION OF THE AUXILIARY EQUIPMENT

- A **power fuse**, of the correct size (*see section 4.3*), must be installed in the positive supply cable, as close as possible to the thruster battery bank and it must be easily accessible and clearly marked.
- A **manual battery isolator**, of the correct size, should be installed in the positive supply cable, as close as possible to the thruster battery bank and must be easily accessible and clearly marked
- An **electrical battery isolator**, as supplied by Max Power, should be installed in the positive supply cable, as close as possible to the thruster battery bank, in order to benefit from all automatic safety features of the electronic control system.
- The thruster **electronic control box** should be installed in proximity of the thruster unit in a completely dry and ventilated area.
- The **control panel(s)** should be installed as desired at the helm station(s) in a protected and waterproof manner.

3. MECHANICAL INSTALLATION

3.1 MOUNTING BASE INSTALLATION

(Please refer to "Build Drawing" at back of this document):

- MAX POWER can supply, either a steel reinforced G.R.P. mounting base or a 5086 aluminium alloy-mounting flange. These bases save considerable shipyard time while assuring solid and precise installation.
 - a) For **GRP hulls** the mounting base should be laminated into the hull. The base supplied is only to help give the initial form; its strength will come from additional lamination (inside and out) added when laminating the hull.
 - b) For **alloy hulls** the mounting flange should be welded onto the base, which has been fabricated into the hull.
- The method and materials used for making the mounting base must be adapted to the particular hull material (laminated wood, GRP, sandwich, aluminium, or steel). Naval Architects, Classification Societies or specialised firms should be consulted.
- The thruster(s) mechanical stresses are spread over the hull by the mounting base. Its installation reinforces the hull, if well calculated, but it might be necessary to attach it by gussets to frames and stringers.
- When setting the mounting base, do not forget to take into account the overall dimensions of the VIP.

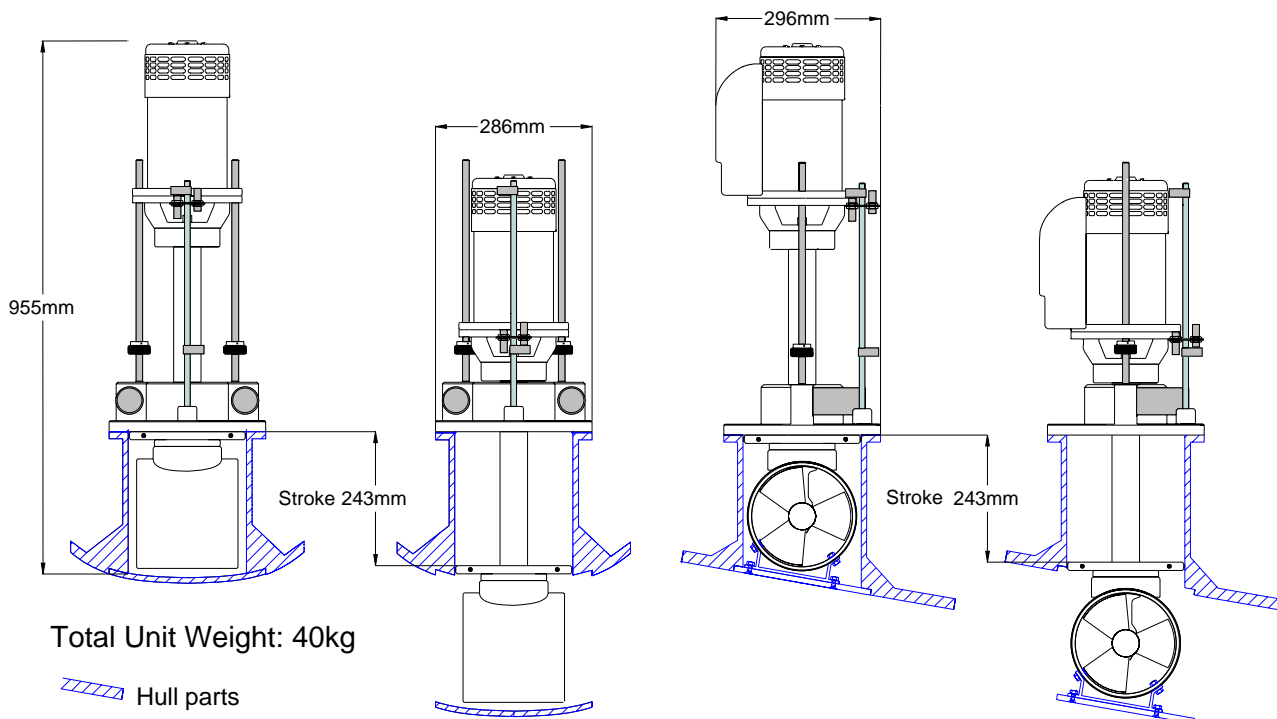

VIP 150, 12/24V Principal Dimensions

- The VIP pushes its thrust plate sideways against the inside of the mounting base when running. This means that one must totally lower the unit and check the following:

- (a) That the VIP's thrust plate is free to move up and down.
- (b) And also that there is no more than 2mm horizontal movement between the thrust plate and the mounting base, especially when fully down.

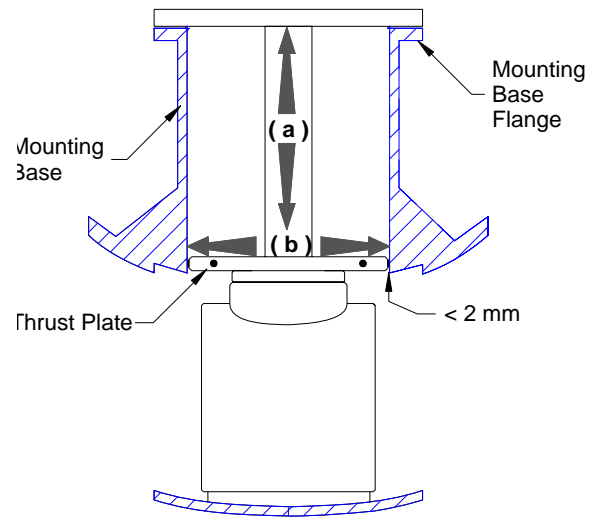

- The mounting base flange should be parallel to the waterline.
- In other words the thruster unit must be installed vertical with its turbine totally clear of the hull in the down position.

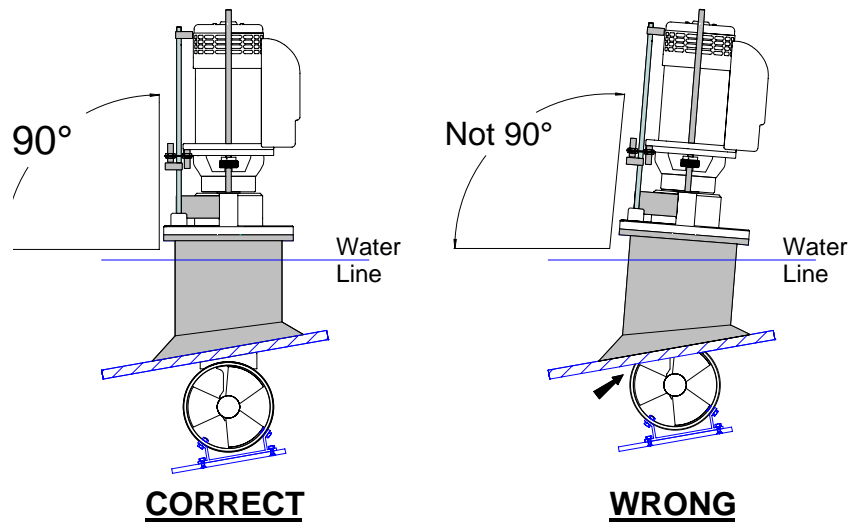

- Before fixing the thruster unit onto the mounting base flange it is important to ensure that the top surface of the mounting base flange is perfectly flat in order to accept the « O » ring seal of the VIP base flange in order to ensure perfect water tightness.
- The bolts fixing the VIP onto the mounting flange must be inserted from top to bottom. Provide sufficient access underneath the flange to allow for tightening the nuts. If the access is not possible, provide a special mounting flange with metric studs or tapped holes.

3.2 CONSTRUCTION OF HULL OPENING & CLOSING PLATE:

- The opening made for the thruster in the hull is closed by a plate, which can be made from the cutout hull section, or specially fabricated.

- a) The closing plate should fit into a 15 – 20 mm wide rebate in the hull when in the raised position. This is to transfer all the seas slamming forces to the hull and not to the electric rams!
- b) The closing plate must be securely fixed to the supplied adjustable aluminium-mounting fitting.
- c) A gasket must be installed in the hulls rebate. This gasket can be made either from neoprene or moulded in «SIKAFLEX» (or similar product). Precautions should be taken to ensure that the gasket does not stick to the closing plate. The plate must rest evenly on this gasket when the thruster is closed.

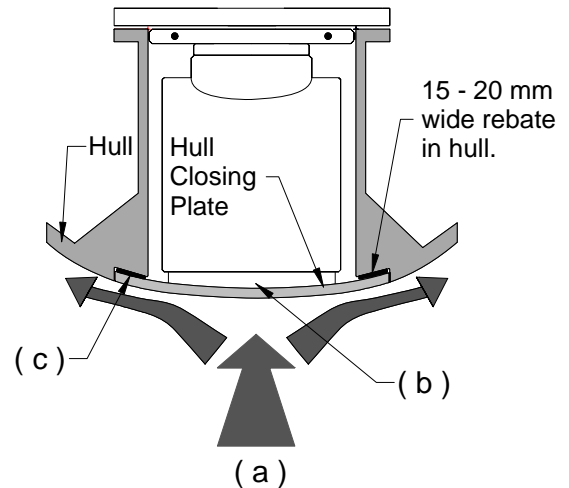

- To prevent marine growth inside the turbine enclosure, it is essential that once the unit is raised, no light be allowed to enter. On an excellent installation the enclosure may even be watertight. If this is achieved anode life will be greatly increased (No circulating water, no oxygen and no corrosion!).
- The use of antifouling or other paints on the thruster unit is not necessary if the closing plate closes properly onto its seal.
 - ⚠ However, if painted, never use copper based paints and do not paint the vertical column of the unit.

3.3 FINAL FITTING OF THE THRUSTER UNIT TO THE MOUNTING BASE:

- Final installation of the thruster unit onto the mounting base must be made after thoroughly cleaning and then liberally coating both joint surfaces (thruster base flange and mounting base flange) with good quality marine grease. This is so that the «O» ring seal is compressed flat, evenly, smoothly and squarely when the bolts are tightened.
- Under no circumstances should the thruster be glued or bedded down with a marine type mastic/glue such as Sikaflex or other similar product(s).
- The flange bolts should be tightened sequentially and in successive passes until the two surfaces touch.

3.4 FINAL ADJUSTMENT OF THE CLOSING PLATE:

- Once the thruster is permanently bolted onto the mounting base, reinstall the closing plate to do the final adjustments.

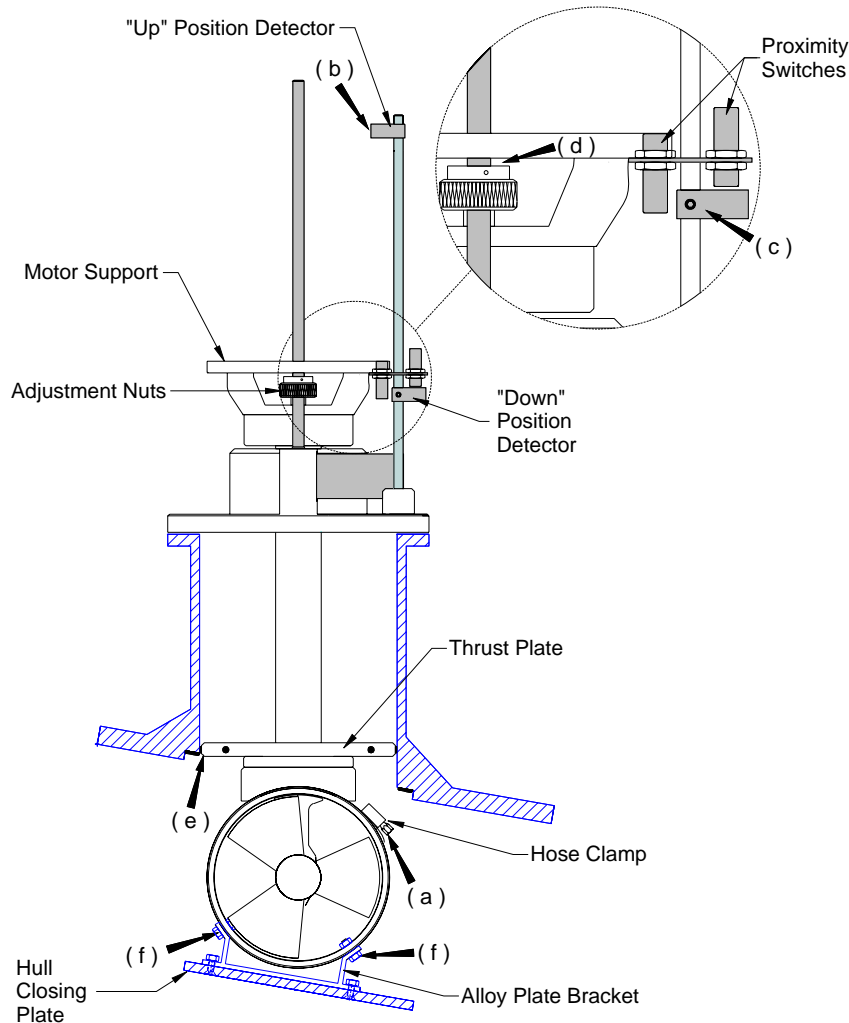

- Lower and raise the turbine to determine correct position of the hull closing plate so that it fits evenly and squarely in the rebate in the hull, then tighten the hose clamps (delivered with unit). The closing plate must rest evenly on its gasket, with pressure so that no upwards movement of the plate is possible even in heavy sea conditions when the hull is subjected to slamming forces.
- Once the hull closing plate adjustment has been completed, adjust the "up" position detector and tighten its grub screw with a 2.5 mm Allen key. This should be done with the unit fully retracted.
- Note that the down position detector is pre-adjusted (before leaving the factory) and should not be touched.
- If re-adjustment is necessary, care should be taken to re-adjust the detector so that adjustment nuts do not touch the motor support when fully down and that the detector grub screw (2.5mm Allen key screw) is tightened down after re-adjustment.
- The thrust plate should not protrude from the mounting base, since it absorbs the horizontal stresses when thrusting or manoeuvring. If protruding, adjust the down position detector as described above.

- f) When finished with the final adjustments, fix the alloy plate bracket by bolting through the GRP turbine in addition to the cable clamps.

-  **IMPORTANT:** Please keep in mind that the power supply to up/down motors is not automatically interrupted if the proximity switches do not detect the position detectors. Care must therefore be taken to remove ones finger from up or down button as soon as the unit blocks in fully up or fully down position when closing plate adjustments are done and if position detectors are not adjusted yet.
- **Installation Advise:** In order to make sure that VIP is raising and lowering smoothly and when closing plate adjustments are made, one can do the following:

- a) Connect 12/24V (depending on thruster voltage) directly to the two up/down motors and simply reverse the polarity to change direction (raise/lower).

 It is **important** to install a 10A fuse in the positive cable and to keep in mind that wires need to be disconnected as soon as the up or down position is reached or as soon as the unit blocks, to avoid damaging the up/down motors.

- b) If the unit blocks before reaching the up/down position or if the unit vibrates excessively when going up/down one needs to adjust the two adjustment nuts to ensure the unit is completely vertical to its base.

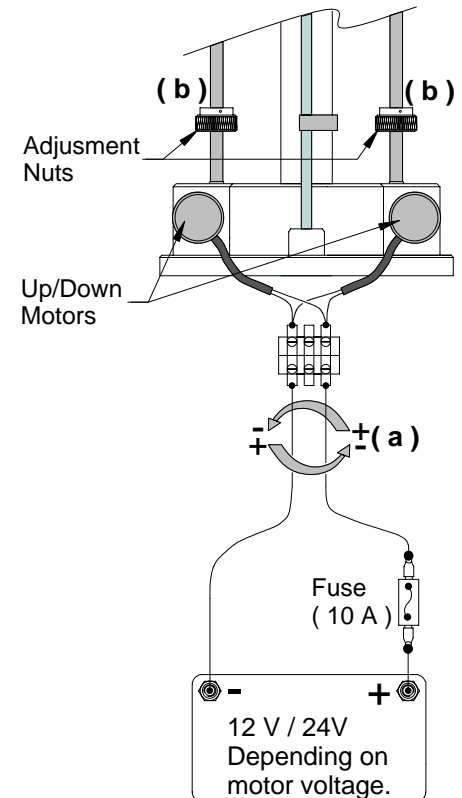

4. ELECTRICAL INSTALLATION

4.1 GENERAL:

- It is important that a qualified marine electrician does the electrical installation, since an incorrect electrical installation will result in the rapid deterioration and/or failure of the unit.
- All electrical components (thruster motor, relay, electronic control box, ect...) should be installed in dry and ventilated areas.
- Under no circumstances should any inflammable products be stored next to the electrical components of the thruster.
- When choosing cable sizes and the battery bank size and type, special care should be given to voltage drops, since excessive voltage drops will cause premature failure of motors and relay contacts.
- Great care should be taken to correctly tighten all electrical connections.

4.2 POWER CABLE SELECTION:

- According to the ISO 10133 standards: *“The length and cross sectional area of conductors in each circuit shall be such that the calculated voltage drop shall not exceed 10% of the nominal battery voltage at any appliance if the circuit is switched on at full load”.*
- The cable lengths as given in the table below are the total length of the positive cable, measured from the thruster battery bank to the thruster, plus the total length of the negative cable measured from the thruster back to the battery bank.

Cable Lengths From battery to thruster (+) & back (-)	VIP 150, 12V		VIP 150, 24V	
	mm ²	AWG	mm ²	AWG
5 m (2 x 2.5m)	95 mm ²	3/0	50 mm ²	1
10 m (2 x 5.0m)	120 mm ²	4/0	70 mm ²	2/0
15 m (2 x 7.5m)	185 mm ²	350MCM	95 mm ²	3/0
20 m (2 x 10m)	240 mm ²	500MCM	120 mm ²	4/0

- When choosing or calculating the cable size needed for your thruster installation, do not forget to take into account the thermal rating of the conductor insulation which are directly related to the ampacity (current carrying capacity) of the cable. Always try to use cables with the highest thermal insulation rating available or at least 85° - 90°C.
- For large diameter cables it may be easier to use two smaller cables instead (in order to allow for a greater flexibility of movement). For example: 2 x 50 mm² instead of 95 mm². Cables at thruster unit should be free to move, without kinking when VIP goes up and down.

4.3 POWER FUSE:

- Sizing of fuses for overcurrent protection are a function of the cable sizes in the circuit, not the amperage drawn by the appliance (thruster motor) in the circuit. It is thus not the electrical thruster motor that is protected by the fuse, but the power cables supplying the thruster motor.
- The Max Power fuse has been application selected for it's time and current characteristics, consequently a much lower rated fuse than traditionally rated may be fitted. Max Power recommends the following fuses and fuse holders as supplied by Max Power:

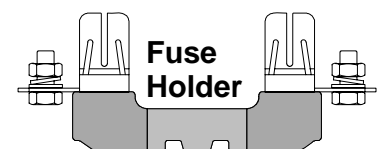
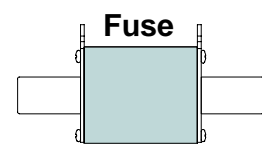

	VIP 150, 12V	VIP 150, 24V
Max Power Fuse Size	315 A	200 A
Regular Fuse Rating	600 A	300 A
Max Power Part Number for fuse.	OPTI 3121	OPTI 3112
Max Power Part Number for fuse holder.	OPTI 3091	OPTI 3119

4.4 BATTERY REQUIREMENTS:

- When choosing the type of batteries needed for your thruster’s battery bank, keep in mind that it is the **CCA** (Cold Cranking Amps) capacity that is the most **important** and not the Ah (Amp-hour) capacity. This is because thrusters draw high currents, but only for very short periods of time (maximum 3 min.)
- Max Power would recommend using Exide, Maxxima 900 type batteries, which have an 800CCA and 50Ah capacity.

VIP 150, 12V	
Type of Batteries	Exide, Maxxima 900
Number of Batteries	2 to 3
Type of Connection	Parallel

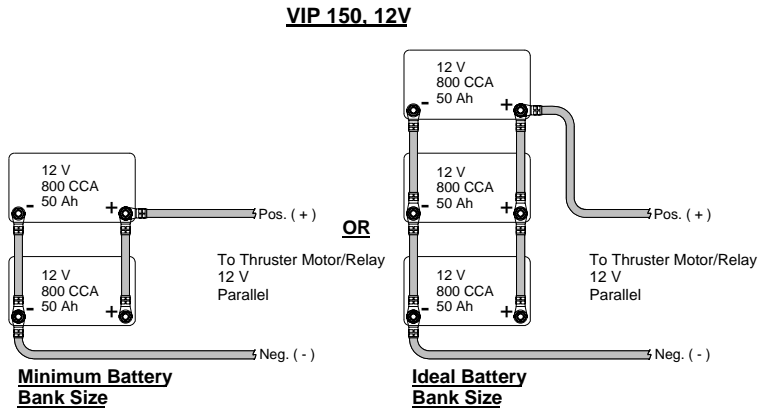

VIP 150, 24V	
Type of Batteries	Exide, Maxxima 900
Number of Batteries	2 or 4
Type of Connection	Series or Series/Parallel

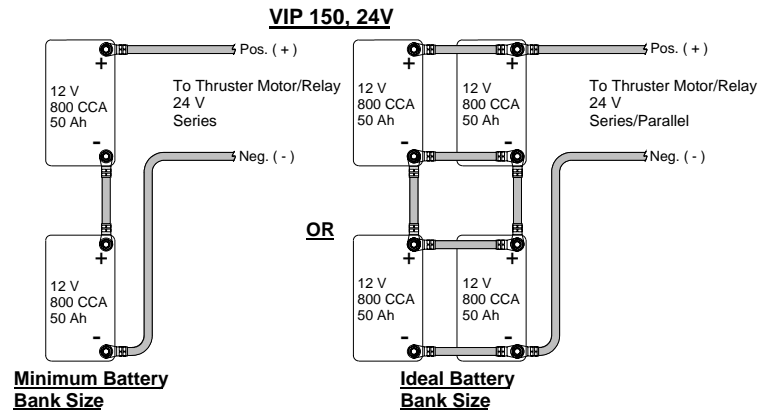

- If the dedicated batteries are charged by the alternator, the reference of the charge must be taken after the diode-splitting block (if in doubt, consult a marine electrician).
- If the batteries or cables are inferior to those recommended, the VIP will not reach its potential thrust. The greater the batteries and cables size, the better the thrust.
- Do not ground the VIP.

4.5 BATTERY ISOLATOR:

- A **manual battery isolator**, of the correct size, should be installed in the positive supply cable, as close as possible to the thruster battery bank and should be easily accessible and clearly marked.
- An **electrical battery isolator**, as supplied by Max Power, should also be installed in the positive supply cable, as close as possible to the thruster battery bank, in order to benefit from all automatic safety features of the electronic control system.

4.6 CONTROL CIRCUIT:

- A double pole isolator/breaker clearly marked “Thruster” should be installed on the yacht’s main equipment breaker board in order to isolate the control circuit and/or power circuit, when thruster is not in use.
- This isolator/breaker should ideally be supplied from an independent battery bank, to the one used for powering the thruster unit.
- Please note that VIP thrusters equipped with an “electronic control box” can only be used with Max Power’s range of control panels as shown in this manual.
- The VIP electronic controller can be supplied in either 12V or 24V, depending on the thruster relay and up /down motor voltage.
- The installer must protect the positive supply cable of the VIP electronic control box by means of a fuse as indicated in the drawing below. The size of the supply wires (red & black) depends on the length of the cable run and the voltage drop in these cables should not exceed 5% of the nominal battery voltage.
- For safety reasons and in order to benefit from all the functions provided by the VIP electronic controller, an electric battery isolator must be installed in the thruster motor’s positive supply cable.

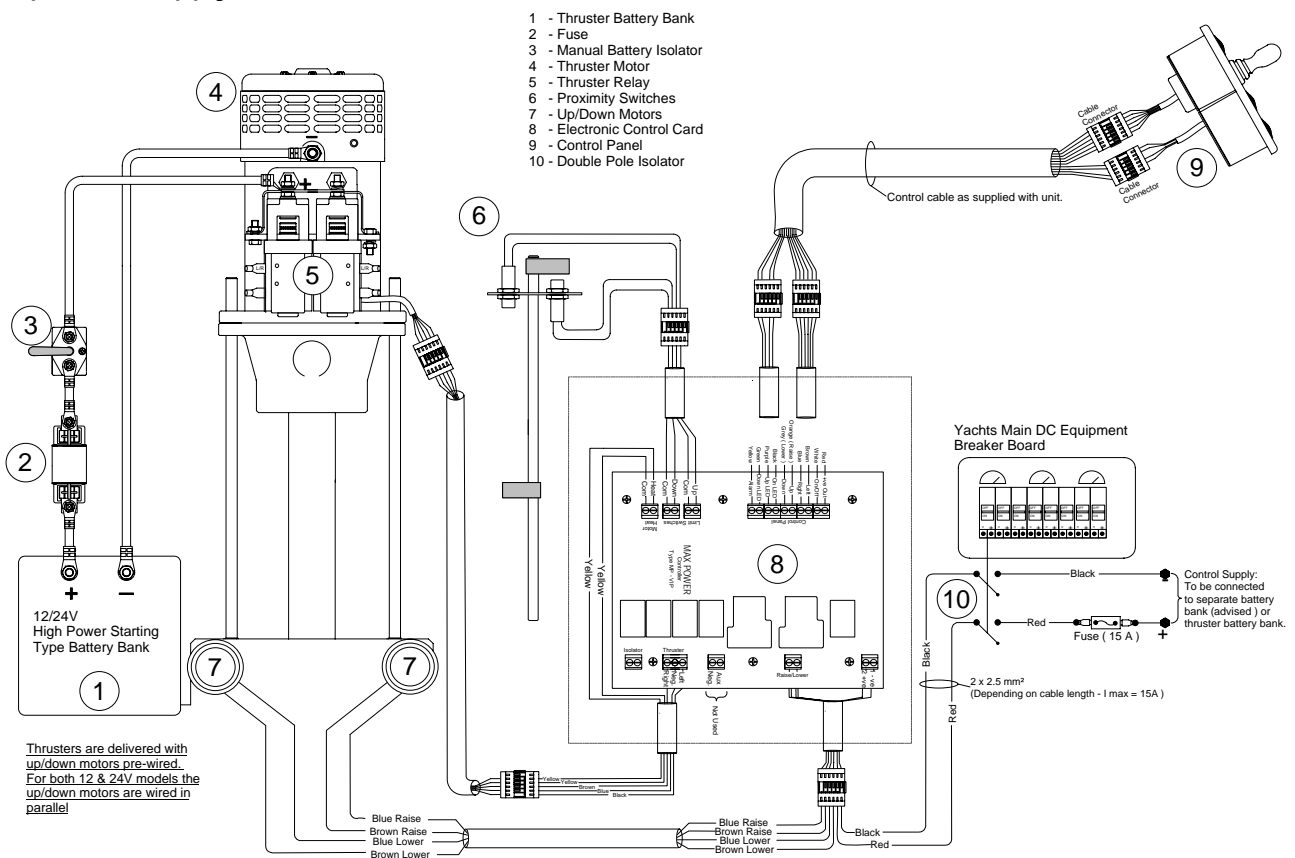

Please refer to the drawings “Wiring Diagram”, “Wiring Loom of Motor/Relay Unit” and “Electronic Control Box Connections” in the back of this manual for more detail on the complete wiring installation.

4.7 CONTROL PANEL AND THRUSTER CONTROL BOX FUNCTIONS:

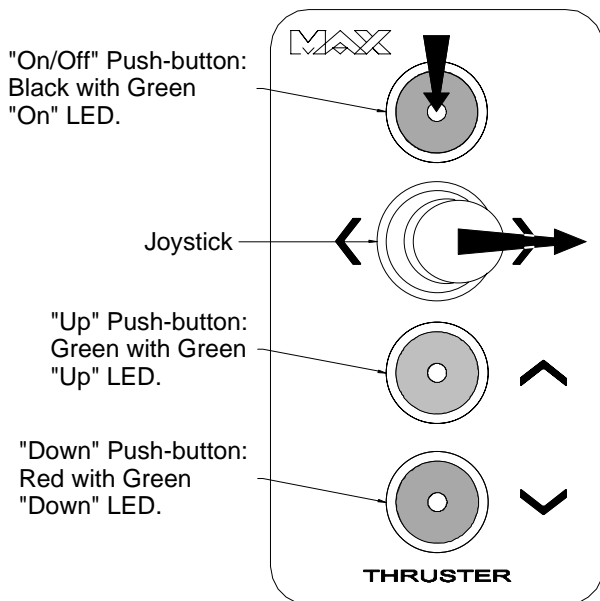

Control Panel:

To switch "ON" or "OFF" push down the black push-button, while pushing joystick to the right for one second.

To "Lower" or "Raise" press and hold the "Down" or "Up" pushbutton until buzzer in control panel double beeps, which indicates unit has reached fully down or fully up position..

4.7.1 Switching System "On" or "Off":

- To switch the thruster "ON" or "OFF" follow the instructions on the diagram above.
- When switched "ON" the unit will double beep and the LED's in the black and green push buttons will light up.
- When switched "OFF" the unit will double beep and the LED's will go out. It's only possible to switch off the unit with thruster in the fully up position.

4.7.2 "Lowering" & "Raising" Thruster Unit:

- Once the unit has been switched on, as described above, press and hold the "Down" pushbutton to lower. The buzzer will start beeping and the "Down" LED will start to flash as soon as the thruster leaves the up position.
- If "Down" or "Up" pushbutton is released before "Down" or "Up" position is detected, the buzzer will start to beep (short) once every 1/2 second and both "Up" & "Down" LED's will start flashing.
- When thruster is detected to be fully down, the "Down" LED comes on and the buzzer double beeps to indicate that thruster is completely down and ready to thrust.
- As long as the thruster is in the "Down" position the buzzer will beep (short) once every three seconds, to indicate that thruster is still in the down position.
- To raise thruster, press and hold the "Up" pushbutton. When thruster is detected to be fully up the "Up" LED comes on and the buzzer double beeps to indicate that thruster is completely up and ready to be switched off.

4.7.3 Thrusting "Left" or "Right":

- a) Use joystick to thrust either left or right.
- b) Please note that it is only possible to thrust left or right when thruster is detected to be fully down.
- c) The thruster controller provides a time delay between left and right thrust in order to avoid rapid direction changes, but no delay when thrusting to same side.

4.7.4 Overheat Alarm & Shut-Down:

- a) If the thruster motor overheats the "On" LED will flash with one-second intervals until the motor has cooled down.
- b)  During this overheat condition one has a total of ten seconds of **actual use** (left & right thrust) of the thruster, after which it will not be possible to continue thrusting in either direction.
- c) The thruster must then be raised by pushing the "Up" push button. Once thruster is detected to be fully up the system will automatically switch off.
- d) After this overheat shut down it will not be possible to switch "On" the system again until the thruster motor has cooled down.

4.7.5 General:

- a) If the thruster unit is in the "Up" position and has not been used for a period of ten minutes, the unit will automatically switch off. Before automatically switching off the unit will warn you by beeping once, followed by a second beep a few seconds later, after which the unit switches off.
- b) In order to isolate the power circuit of the thruster motor each time the control circuit is switched off, one would need to install an electric battery isolator, as advised by Max Power (see "*Wiring Diagram*" in the back of this manual for more detail).
- c) When electronic control box is powered up and "Up" position detector is not detected, the "Up" LED will start flashing and the buzzer will beep once every second. The "Up" push-button should then be pressed until unit is detected to be fully "Up". After which the buzzer will beep twice and the system will be switched off automatically.

5. TESTS and CHECKS

5.1 BEFORE LAUNCHING:

- a) Raise and lower thruster.
 - b) Check that the hull closing plate shuts firmly.
 - c) Confirm that all bolts have been sufficiently tightened, especially the base bolts.
 - d) Correct the adjustment of the position detectors, if needed.
- If the up/down motors function the wrong way round, reverse the two wires connected to the up/down motors.
 -  Never test the thruster to the left or right with the boat out of the water. This is due to the risk of injuries and the risk of damage to the thruster motor and relay.

5.2 AFTER LAUNCHING:

- a) Check the water tightness of the thruster installation.
 - b) Turn on power to both circuits (power and control).
 - c) Thrust tests must be carried out under NORMAL conditions:
 - with the batteries fully charged and in good condition.
 - with the engine running and the alternator charging the batteries.
- If the joystick is pushed to the left and the boat moves to the right, inverse the brown and blue control wires, going to the thruster relay.

6. OPERATION LIMITATIONS

- Never leave the **VIP** in the down position when not in use. Any calcium, or shellfish deposits that accumulate after a long period in the down position will deteriorate the column's water seal.
-  The **VIP** must be in the up position during normal navigation. The **VIP** should only be used under conditions with less than 5 knots forward speed. Examples - berthing manoeuvres, assisting a tack in light air.
- Please note that the electric motor of the VIP is rated S2-2min. This means the motor can run continuously for 2 minutes, after which it should be stopped for a sufficient time to cool down to the ambient temperature.
- Please keep in mind that the supply to the up/down motors is not automatically interrupted if the proximity switches do not detect the position detectors. Care must thus be taken to remove ones finger from the up or down button as soon as unit blocks, before fully up or down positions are reached.
- The **VIP** thruster should always be used when the batteries are fully charged and the with the engine alternator running. Discharged batteries will damage the motor and/or relay.

7. BASIC MAINTENANCE:

7.1 CONTROL PANEL:

- a) Control panel(s) should be protected from the natural elements while the thruster is not in use.
- b) The area behind the dashboard should be kept dry at all times to avoid the risk of oxidation of the cable connector contacts.

7.2 THRUSTER MOTOR & RELAY:

- a) Remove and clean out dust from motor-brushes with compressed air once every year.
- b) The electric motor must be kept dry and aerated.

7.3 BATTERIES:

- a) Check regularly the condition of the batteries used for the thruster and its charging system.
- b) Weak batteries (low voltage) are the most frequent cause of rapid deterioration of the thruster relay and motor.

7.4 COMPOSITE DRIVE LEG:

- a) The composite drive leg is lubricated for life
- b) The composite drive leg does not require an anode.
- c) When the boat is ashore, check for evidence of fishing line, etc... in the propellers.
- d) For prevention of calcium build up on the drive shafts, which would damage the oil seals, before fitting the propeller(s), cover drive shaft and the oil seals stainless steel cover with silicon grease. This should be done on an annual basis after cleaning of outside of leg.
- e) Do not use aggressive solvents as they might damage drive leg seals.
- f) If drive leg oil seals are found to be worn, replace drive leg with exchange unit.
- g) Always keep the propellers and tunnel clean.
- h) Please contact your closest Max Power distributor for local service points.

7.5 BRONZE DRIVE LEG:

- a) Check the oil in the leg every year, and change if necessary (oil drain plug is under the anode - copper joint should be changed).
- b) The anode should be frequently checked and changed when necessary (At least every year).
- c) When the boat is ashore, check for evidence of fishing line, etc... in the propellers.
- d) For prevention of calcium build up on the drive shafts, which would damage the oil seals, before fitting the propeller(s) cover drive shaft and oil seals, with silicon grease. This should be done on an annual basis after cleaning of outside of leg.
- e) Do not use aggressive solvents as they might damage drive leg seals.
- f) Always keep the propellers and tunnel clean.
- g) Do not paint the anode.
- h) Please contact your closest Max Power distributor for local service points.

7.6 GENERAL:

- a) Regularly check that the power cable connections are tightened correctly and that they are free to move when VIP is going up/down, and that they are in good condition.
- b) If the vessel is to remain out of the water for some time, for example dry storage for winter, the underwater mechanism must be thoroughly rinsed with fresh water, then the thruster column must be liberally greased.
- c) Inspect and repair the hull closing plate gasket for deterioration or missing pieces. Check and tighten, if necessary, the hull fixing plate bracket screws.
- d) Every two years change column seal, part number 52 on parts list.

For more detailed maintenance procedures, please contact your closest Max Power distributor (See "*Distributor Contact List*") for further assistance.

**A copy of this manual must remain
on board for consultation.**

8. DRAWINGS & DIAGRAMS:

8.1 PRINCIPAL DIMENSIONS:

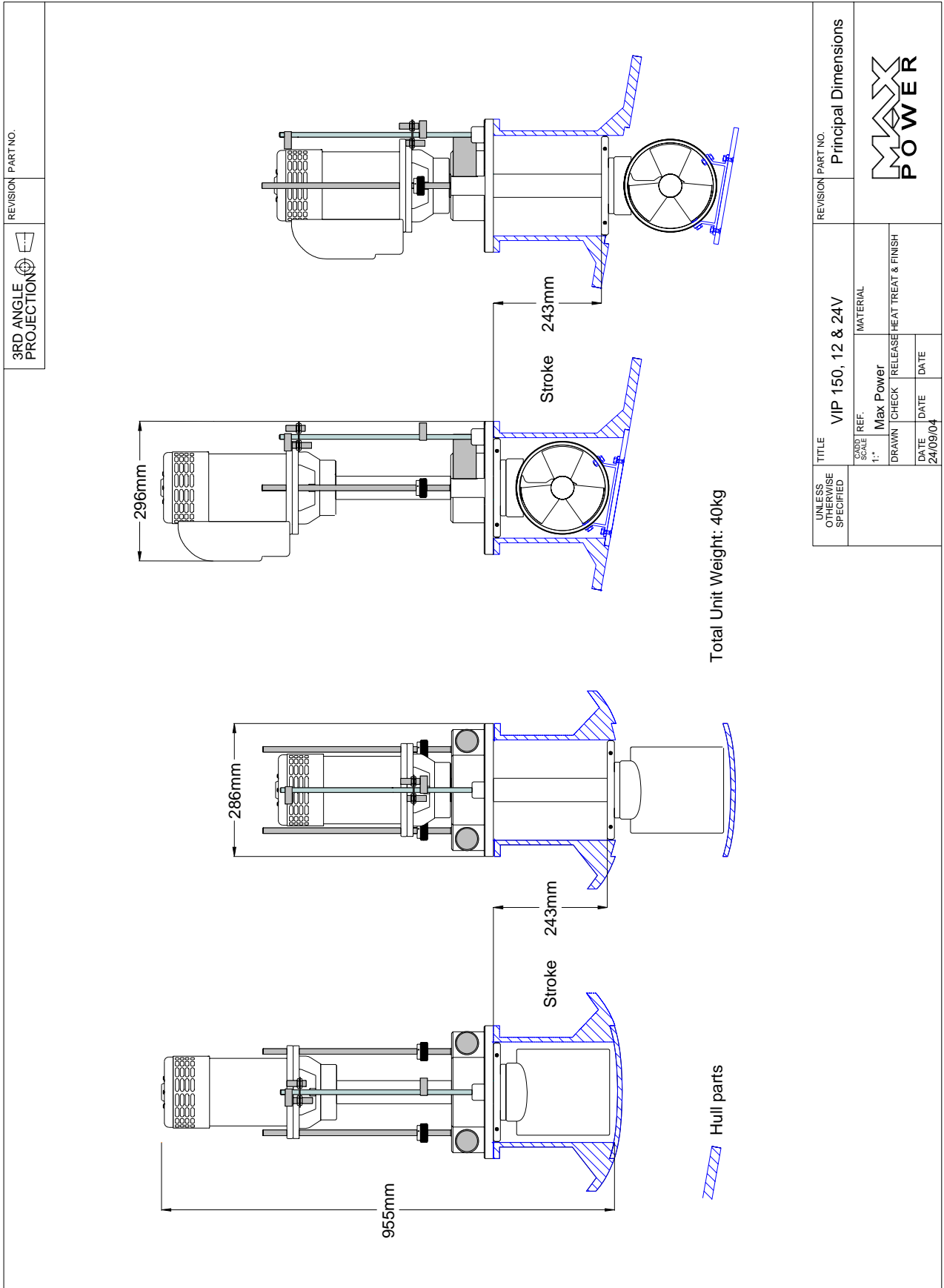

8.2 BUILD DRAWING:

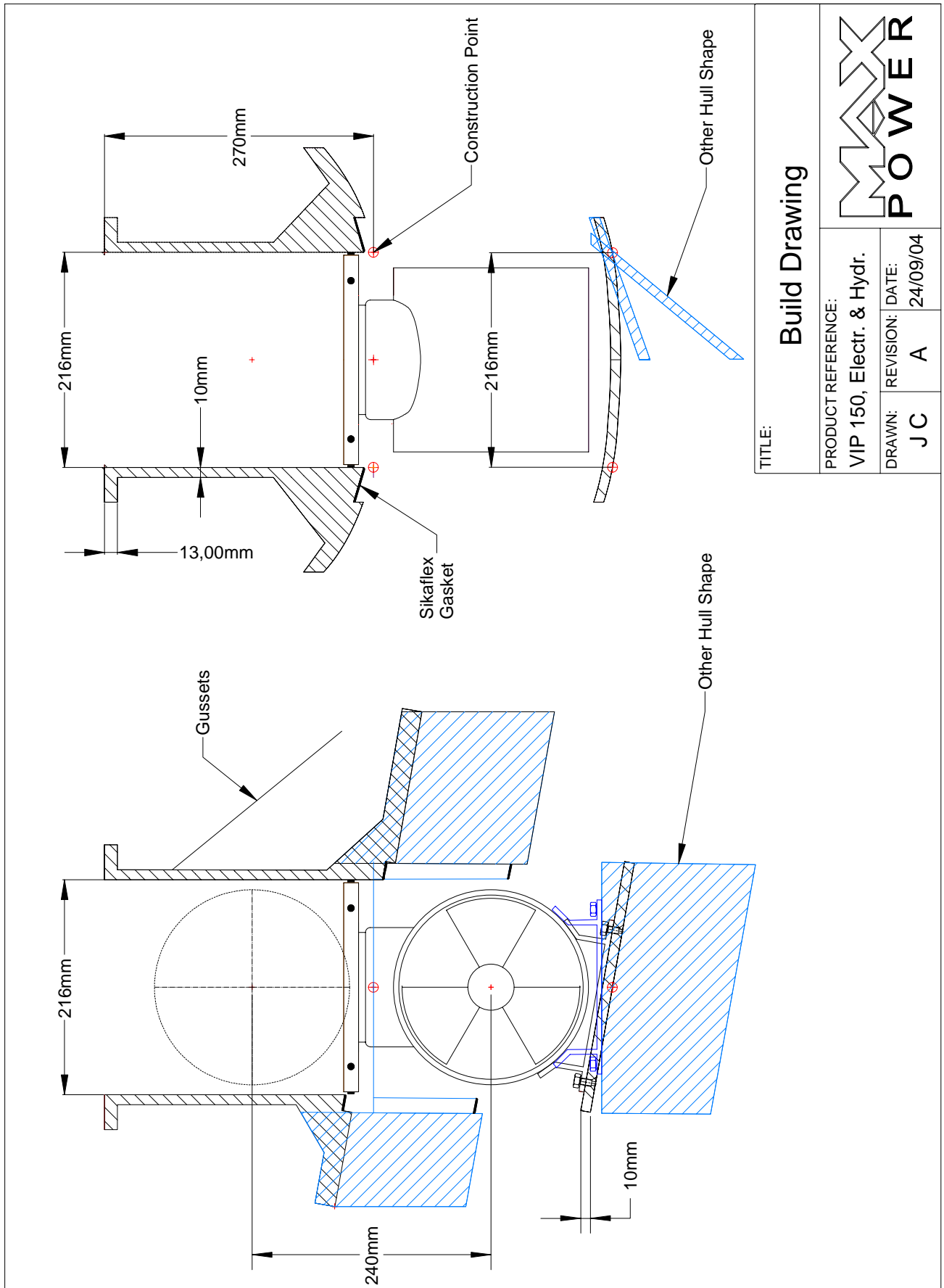

8.3 WIRING DIAGRAM:

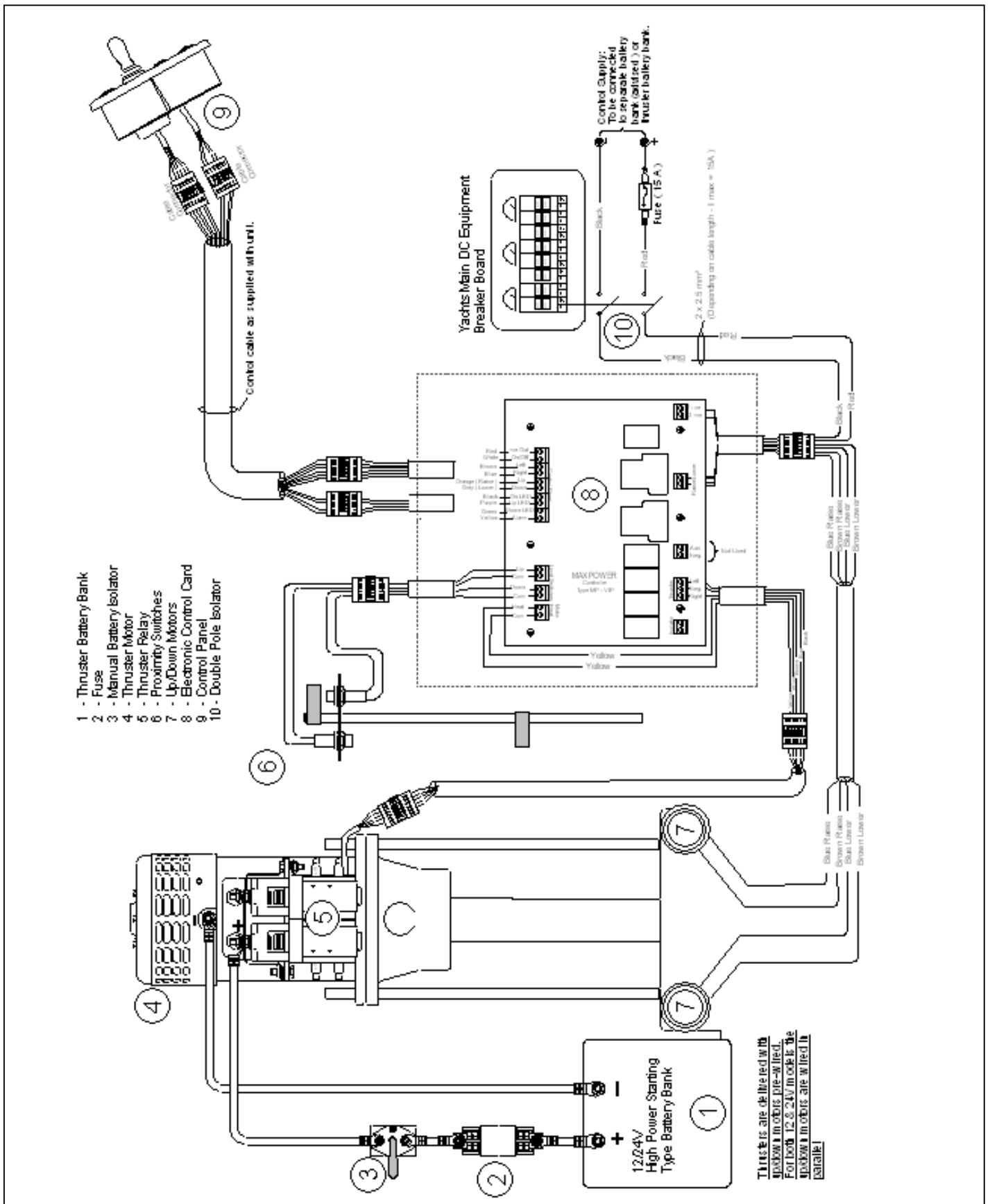

8.4 ELECTRONIC CONTROL BOX CONNECTIONS:

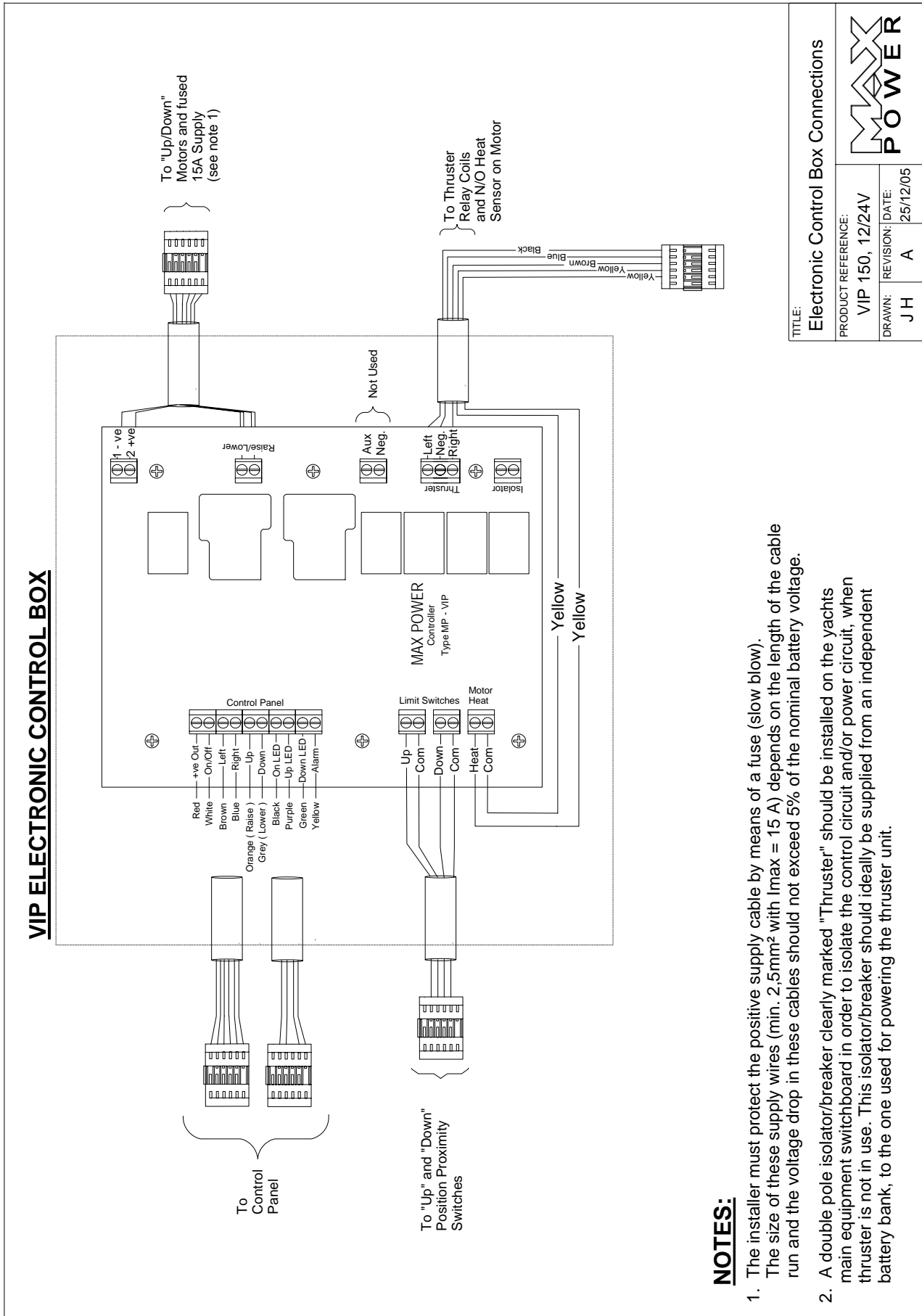

NOTES:

1. The installer must protect the positive supply cable by means of a fuse (slow blow). The size of these supply wires (min. 2,5mm² with I_{max} = 15 A) depends on the length of the cable run and the voltage drop in these cables should not exceed 5% of the nominal battery voltage.
2. A double pole isolator/breaker clearly marked "Thruster" should be installed on the yacht's main equipment switchboard in order to isolate the control circuit and/or power circuit, when thruster is not in use. This isolator/breaker should ideally be supplied from an independent battery bank, to the one used for powering the thruster unit.

TITLE: Electronic Control Box Connections	
PRODUCT REFERENCE: VIP 150, 12/24V	REVISION/DATE: A 25/12/05
DRAWN: JH	



8.5 WIRING OF ADDITIONAL CONTROL PANELS FOR VIP THRUSTERS:

9. PARTS LISTS & DIAGRAMS :

9.1 PARTS LIST & DIAGRAM: A

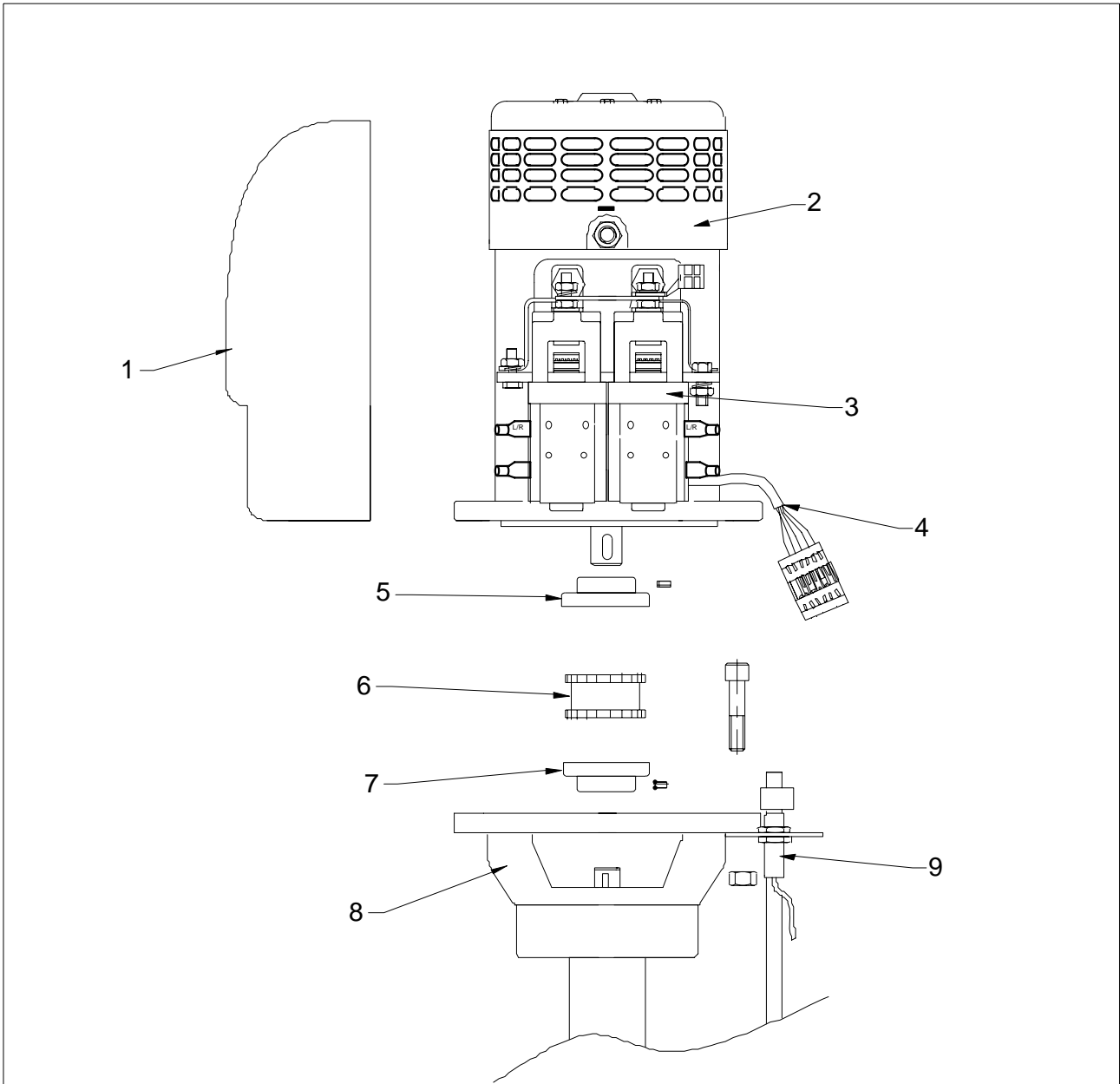

N°	DESCRIPTION:	Qty.	REFERENCE:
1	Motor Relay Cover	1	MP082021
2	Electric Thruster Motor 12V	1	MP083010
2	Electric Thruster Motor 24V	1	MP083011
3	Complete Thruster Relay 12V	1	MP083053
3	Complete Thruster Relay 24V	1	MP083054/2
4	Motor/Relay Wiring Loom	1	VP088051
5	Coupling Motor Side	1	MPOP5140
6	Rubber Coupling	1	MPOP5150
7	Coupling Drive Leg Side	1	MPOP5130
8	Motor Support	1	MP085030
9	Proximity Switch	2	OPTI3350

TITLE: Parts List: A		
PRODUCT REFERENCE: VIP 150, Electric		
DRAWN: JC	REVISION: A	DATE: 15/12/04
MAX POWER		

9.2 PARTS DIAGRAM: B

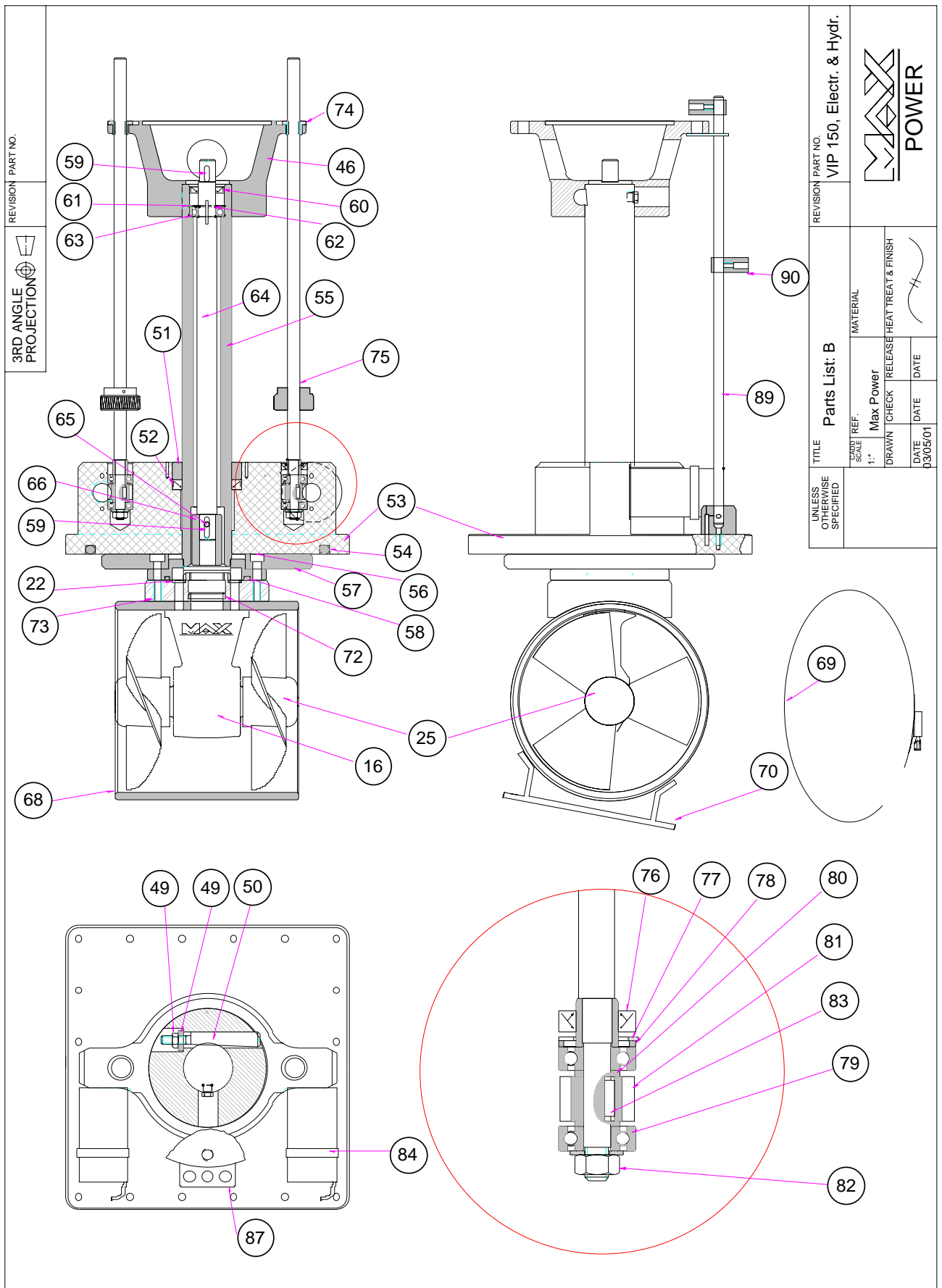

9.3 PARTS LIST: B

N°	Description	Q	Reference
16	Composite Leg	1	MP088100
22	Leg Bolts	2	MPOP 5340
25	Propeller	2	MPOP 5230
26	Propeller Grub Screw	2	OPTI 4040
27	Propeller Pin	2	MPOP 5220
48	Nyloc Nut 8mm	1	VPO8 4190
49	Machine Washer	1	VPO8 5390
50	Coter Pin	1	VPO8 5380
51	Water Gland Retaining Ring	1	VPO8 5400
52	Water Gland	1	VPO8 5490
53	Sliding Shaft Plate	1	VPO8 5330
54	Shaft Plate O - Ring	1	VPO8 5460
55	Sliding Shaft	1	VPO8 5310
56	Sliding Shaft Bolt	2	VPO8 4100
57	Torque Transmission Plate	1	VPO8 5320
58	Sliding Shaft O - Ring	1	VPO8 5450
59	Shaft Key	1	VPO8 5420
60	Drive Shaft Oil Seal	1	VPO8 5480
61	Circlip	1	VPO8 5500
62	Circlip	1	VPO8 5510
63	Shaft Bearing	1	VPO8 5470
64	Drive Shaft	1	VPO8 5300
65	Grub Screw	2	VPO8 4140
68	Propeller Housing	1	VP08 2020
69	Tunnel Clamp	2	VPO8 5530
70	Closing Trap Support Plate	1	VPO8 5580
71	BS Seal	2	VPO8 5430
72	O - Ring	1	VPO8 5440
73	Adapter	1	VPO8 5350
74	Drive Nut	2	VP085004
75	Drive Screw	2	VP084042
76	Seal	2	VP085008
77	Circlip	2	VP085003
78	End Float Spacer	2	VP085005
79	Screw Bearing	4	VP085001
80	Washer	4	VP085007
81	Wheel	2	VP085000
82	Nut 8mm	2	
83	Drive Screw Key	2	VP085010
84	Electric Motor 12V	2	RT203121
85	Electric Motor 24V	2	RT203122
86	Motor Screw 4 mm	4	VP084160
87	Position Switch Holder	1	VP085620
89	Position Detector Rod	1	VP085581
90	Position Detector	2	VP083200

10. WARRANTY COVERAGE :

The purpose of this document is to set out the terms of warranty cover offered in relation to products purchased by the End User from Max Power or its approved network of resellers. This document will adhere to the following format:-

10.1 DEFINITIONS

Authorized Repair Number – The number given by Max Power on reporting a fault with your thruster

Dealer – An authorized Max Power sales centre

End User – The boat supplied with supplied equipment and the owner thereof

Installer – The authorized centre responsible for the installation of your thruster

Manufacturer – supplier of the equipment under warranty

Pleasure Craft – Vessels used for owner's personal use that have no commercial use (i.e Charter boats or work boats)

Resellers – Max Power approved distributors and dealers

Serial Number – Number in upper right hand corner of Warranty document

Supplier – The manufacturer (Max Power)

Warranty – The terms and conditions that are covered by the manufacturer

10.2 PERIOD OF COVERAGE

The equipment manufactured by the Supplier is guaranteed to be free from defective workmanship, components and materials under normal usage conditions for a period of two years from the date of purchase by the End User. This warranty is transferable to subsequent owners of this equipment during the period of coverage. If the material is used for anything other than for pleasure craft, the guarantee is limited to a six-month period.

10.3 WARRANTY REGISTRATION

Register your purchase now to receive free extended warranty coverage. This can be done using one of the following methods (NB. proof of purchase must be included to establish that equipment is still under warranty):

- a) The quickest and easiest method to register your warranty is to fax the attached installation check list and warranty registration to the Manufacturer (Fax: +33 4 92 19 60 61)
- b) Mail in your warranty registration document, please ensure that you make a copy before sending it. (10 Allée F Coli, 06210 Cannes-Mandelieu, France).

10.4 WARRANTY TERMS

Year 1 All factory testing, diagnosis, repairs and replacements are performed at no charge to the End User. All parts and up to two hours of labour are covered for repairs and replacements conducted in the field.

Year 2 All factory testing, diagnosis, repairs and replacements are performed at no charge to the End User. This excludes any damage or faults occurring from normal wear and tear on the following items: engine, oil seals, relay contacts (If warranty is registered within the 3 month period following installation), also excluded labour & shipping costs.

10.5 WARRANTY EXCLUSIONS

Damage due to modifications or installation contrary to published specifications
 Cost of hauling the boat
 Damage due to repairs performed by an unauthorized service centre
 Damage due to lack of normal maintenance services
 Damage due to water
 Parts replaced due to normal wear and tear
 Repairs performed without knowledge of manufacturer (please contact dealer to receive Repair Authorization Number)
 Tampering of equipment by the End User
 Cost of travel to and from the job site
 Cost of economic loss, including injury to any person, damage to property, loss of income or profit, communication, lodging, inconvenience
 Consequential damage due to failure, including those arising from collision with other vessels or objects

10.6 PROCEDURAL GUIDELINES

PLEASE VIEW THE TROUBLE SHOOTING LIST TO ASCERTAIN OR SOLVE ORIGIN OF PROBLEM PRIOR TO CONTACTING THE DEALER/INSTALLER

- 1) Contact your dealer/installer to report the problem.
 - a) If you do not know who this is, contact the nearest Max Power distributor.
 - b) If you are in foreign waters please contact the nearest Max Power distributor.
- 2) Ensure you have the serial number and model number of your thrusters unit at hand.
- 3) Dealer/Installer will come to site to decipher the cause of the fault.
- 4) If the cause of fault is due to a manufacturing problem the dealer will contact Max Power to receive Repair Authorization Number.
- 5) If the problem is due to an installation error please contact your installer.

DISTRIBUTER CONTACT LIST:

SOUTHERN EUROPE:

<p><u>CYPRUS</u> OCEAN MARINE EQUIPMENT LTD Limassol Tel: + 357 53 69 731 Fax: + 357 53 52 976 Email: oceanm@spidernet.com.cy</p>	<p><u>CYPRUS</u> TUTI MARE TRADING Limassol Tel: + 357 25 431 313 Fax: + 357 25 431 300 Email: tutimare@cytanet.com.cy</p>
<p><u>FRANCE</u> ACCASTILLAGE BERNARD Cannes La Bocca Tel: + 33 493 90 47 47 Fax: + +33 5 46 45 49 53 Email: t.barrez@accastillage-bernard.fr</p>	<p><u>GREECE</u> ALEX MARINE Piraeus Tel +30 10 41 29 539 Fax: + 30 10 41 12 932 Email: alexmarine@otenet.gr</p>
<p><u>ITALY</u> SIEMENS VDO Trading Srl. Novate Milanese(MI) Tel: + 39 0235 6801 Fax: + 39 0238 204 339 Email: piergiorgio.allaria@siemens.com</p>	<p><u>PORTUGAL</u> PLASTIMO PORTUGAL (SIROCO) Lisbon Tel: + 351 21 362 04 57 Fax: + 351 21 362 29 08 Email: plastimo@siroco-nautica.pt</p>
<p><u>SPAIN</u> ACASTIMAR Cambrils Tarragona Tel: + 349 77 36 2118/9074 Fax: + 349 77 36 2687 Email: acastimar@acastimar.com</p>	<p><u>TURKEY</u> EGEMAR Tuzla - Istanbul Tel:+90 216 494 21 68 Fax:+90 216 494 22 18 Email: sales@egemar.com</p>
<p><u>CROATIA</u> ANORTI ADRIA Mirosevecka c 122, Zagreb Tel: +385 98 1896 770 Fax: +385 23 386 075 Email: info@anortiadria.hr</p>	<p><u>SLOVENIA</u> ANORTI Kavciceva 66 Ljubljana Tel: +386 1 544 6436 Fax: +386 1 544 6435 Email: info@anorti.si</p>
<p><u>MALTA</u> STRAND MARINE Triq Is Sebh, Qormi Tel: +356 21 472 336 Fax: +356 21 472 338 Email: info@strandmarinemalta.com</p>	

NORTHEN EUROPE:

<p><u>DENMARK</u> PALBY MARINE Vejle Tel: + 45 75 88 13 11 Fax: + 45 75 88 17 01 Email: palby@palby.dk</p>	<p><u>GERMANY</u> LEAB Schlieswig, Busdorf Tel.: +49 4621- 36 06 67 Fax: +49 4621- 36 06 69 Email: info@leab.de</p>
<p><u>ICELAND</u> VELASALAN 101 Reyjavik Tel : +354 580 5312 Fax : +354 580 5301 Email: Stefan@velasalan.i</p>	<p><u>HOLLAND & BELGUIM</u> NAVIMO HOLLAND Schoonhoven Tel: +31 182 320 522 Fax: +31 182 320 519 Email: info@plastimo.nl</p>
<p><u>FINLAND</u> MASTERVOLT FINLAND Raisio Tel: + 358 2 4339990 Fax: + 358 2 4350085 Email: info@mastervolt.fi</p>	<p><u>HOLLAND</u> KEMPER EN VAN TWIST Dordrecht Tel: + 31 078 61 30 155 Fax: + 31 078 61 36 746 Email: cscheepbouwer@kvt.nl</p>

<p><u>NORWAY</u> PROGRESS INGENIORFIRMA AS Kjeisaas Tel: + 47 22 02 79 00 Fax: + 47 22 02 79 01 Email: thomas@progressing.no</p>	<p><u>SWEDEN</u> PLASTIMO NORDIC Henan Tel: + 46 304 360 60 Fax: + 46 304 307 43 Email: mikael.andersson@navimo.se</p>
<p><u>U.K</u> PLASTIMO UK Eastleigh, Hampshire Tel: + 44 870 751 4666 Fax: + 44 870 751 1950 Email: sales@plastimo.co.uk</p>	<p><u>U.K.</u> AR PEACHMENT Norfolk Tel: + 44 1603 714 077 Fax: + 44 1603 714 211 Email: kevin@peachment.co.uk</p>

AMERICAS :

<p><u>ARGENTINA</u> BARON SRL Buenos Aires Tel: + 54 11 4580 55 56 Fax: + 54 11 47 46 16 96 Email: Admin@baron.com.ar</p>	<p><u>CANADA</u> REKORD MARINE ENTERPRISES LTD Vancouver Tel: + 1604 325 52 33 Fax: + 1604 325 03 26 Email: michael@rekord-marine.com</p>
<p><u>BRAZIL</u> SAILING PRODUCTS Rio de Janeiro Tel: + 55 21 494 7222 Fax: + 55 21 494 7223 Email: spsail@ibm.net</p>	<p><u>U.S.A.</u> SCANDVIK Vero Beach, Florida Tel: + 1 561 567 28 77 Fax: + 1 561 567 91 13 Email: sales@scandvik.com</p>

AUSTRALIA & SOUTH EAST ASIA:

<p><u>AUSTRALIA</u> OCEANTALK Sydney Tel: + 612 9981 9500 Fax: + 612 9981 9555 Email: rk@oceantalk.com.au</p>	<p><u>NEW ZEALAND</u> POWER & MARINE Wiri Auckland Tel: + 64 9 914 55 55 Fax: + 64 9 914 55 88 Email: sales.staff@powermarine.co.nz</p>
<p><u>CHINA</u> RONSIL DEVELOPMENT Hong Kong Tel: + 852 2834 1633 Fax: + 852 2834 0201 Email: ronsil@netnavigator.com</p>	<p><u>CHINA</u> HOLYLIGHT TRADING Hong Kong Tel: + 852 2543 7048 Fax: + 852 2543 6156 Email: coha@biznetvigator.com</p>
<p><u>JAPAN</u> KAZ MARINE Yamato City, Kanagawa Tel: +81 46 268 41 01 Fax: +81 46 268 4351 Email: kazplast@olive.ocn.ne.jp</p>	<p><u>SINGAPORE</u> OCEANTALK ASIA Singapore Tel: + 65 6543 4041 Fax: + 65 6543 4042 Email: lee@oceantalk.com.sg</p>
<p>MIDDLE EAST & AFRICA <u>ISRAEL</u> YAMIT PO Box 6158 Tel Aviv Tel: + 972 3 527 1779 Fax: + 972 3 527 1031 Email: office@yamit.co.il</p>	<p><u>SOUTH AFRICA</u> MANEX & POWER 5 Industry Street Paarden Eiland Tel: + 27 21 511 72 92 Fax: + 27 21 510 14 89 Email: manex@manex.co.za</p>

Serial N°:



WARRANTY FORM

VERY IMPORTANT

Please complete this form and fax a *COPY* to Max Power with a copy of the installation invoice or the invoice of the yacht/boat in order for the warranty to come into effect.

To Be Completed by Owner:

Name of Owner:..... Contact No. :.....
 Address:E-mail:
 Country:.....Postcode:
 Name of Skipper:..... Contact No. :.....
Signature of Owner:Date:

To Be Completed by Installer:

Installation Details:

Thruuster Model :..... Electric/Hydraulic :.....
 Date of Installation :..... Date of Launching Boat :
 Type and model of Boat :Builder:..... Build Year:
 Pleasure or Commercial craft?:..... Sail or Motor: Rig:.....
 Navigates at Sea or River or Canals?..... Hull construction material :.....
 L.O.A. :.....L.W.L. :.....Beam :..... Free Board:.....
 Displacement Weight at Full Load: :..... Height & Length of Superstructure:.....
 Tunnel Diameter, Thickness, Material & Length:.....
 If Electric, Battery Type, Size & Number:

Installation Checks:

Before Operating Thruuster	While Operating Thruuster
<u>Electrical:</u> Voltage at Batteries.....
Voltage at Thruuster Motor
Charge at Alternator in Amps
Ampere in Motor Power Circuit
<u>Mechanical:</u>	
Verify if drive coupling between motor and drive leg is correctly tightened:..Yes / No	
Verify if all cable connections is sufficiently tightened:.....Yes / No	
If hydraulic verify all hydraulic connections:Yes / No	
Thruuster installation tested and working correctly:Yes / No	

Important: Refer to installation manual for full installation details.

Name of Installer: Signature:.....

PLEASE RETURN BY FAX: + 33 4 92 19 60 61
 TO GAIN YOUR EXTRA WARRANTY COVERAGE